

Volume 4



OMCS CLASS

Overseas Marine Certification Services

Your Reliable
Classification Society





OMCS CLASS
Overseas Marine Certification Services

ELECTRICAL INSTALLATIONS

VOLUME IV

Copyright ©2013
Overseas Marine Certification Services
OMCS CLASS



CHAPTER 1 GENERAL PROVISIONS

1.1	GENERAL REQUIREMENTS	1
1.1.1	GENERAL REQUIREMENTS	1
1.1.2	DEFINITIONS	1
1.1.3	PLANS AND DOCUMENTS	4
1.1.4	TESTING	7
1.2	OPERATING CONDITIONS	7
1.2.1	ENVIRONMENTAL CONDITIONS	7
1.2.2	VOLTAGE AND FREQUENCY FLUCTUATIONS	8
1.2.3	HARMONICS CONTENT	8
1.3	DESIGN, CONSTRUCTION AND INSTALLATION	9
1.3.1	GENERAL REQUIREMENTS	9
1.3.2	TYPE OF PROTECTIVE ENCLOSURES	10
1.3.3	EXPLOSION PROTECTION	15
1.3.4	EARTHING	17
1.3.5	ELECTROMAGNETIC COMPATIBILITY	19
1.3.6	VISUAL AND ACOUSTICAL SIGNAL	20
CHAPTER 2: ELECTRICAL INSTALLATIONS IN SHIPS		
2.1	MAIN SOURCE OF ELECTRICAL POWER	21
2.1.1	GENERATING SETS	21



2.1.2	GENERATORS DRIVEN BY MAIN PROPULSION MACHINERY (SHAFT-DRIVEN GENERATORS)	22
2.1.3	TRANSFORMERS	23
2.1.4	INSTALLATION OF SWITCHBOARD	23
2.2	EMERGENCY SOURCE OF ELECTRICAL POWER	24
2.2.1	GENERAL REQUIREMENTS	24
2.2.2	SCOPE AND PERIOD OF SUPPLY OF THE EMERGENCY SOURCE IN PASSENGER SHIPS	26
2.2.3	SCOPE AND PERIOD OF SUPPLY OF THE EMERGENCY SOURCE IN CARGO SHIPS	28
2.3	EXTERNAL POWER SOURCE	30
2.3.1	SHORE SUPPLY	30
2.4	POWER SUPPLY AND DISTRIBUTION	
2.4.1	POWER SUPPLY AND DISTRIBUTION SYSTEMS	30
2.4.2	INSULATION DISTRIBUTION SYSTEM	31
2.4.3	EARTHED AND HULL RETURN SYSTEM OF DISTRIBUTION	31
2.4.4	VOLTAGE AND FREQUENCY	32
2.4.5	BALANCE OF LOADS	33
2.4.6	DIVERSITY FACTORS	33
2.4.7	POWER SUPPLY TO ESSENTIAL EQUIPMENT	34
2.4.8	POWER SUPPLY TO RADIO EQUIPMENT AND NAVIGATION EQUIPMENT	34
2.4.9	POWER SUPPLY TO AUXILIARY MACHINERY MOTORS, ETC.	35
2.4.10	SOCKETS	35



2.5	PROTECTION	35
2.5.1	GENERAL REQUIREMENTS	35
2.5.2	CALCULATIONS OF SHORT-CIRCUIT CURRENT	36
2.5.3	CHOICE OF PROTECTIVE DEVICES AGAINST SHORT-CIRCUIT	36
2.5.4	SELECTIVE PROTECTION FOR SHORT-CIRCUIT	36
2.5.5	CHOICE OF PROTECTIVE DEVICES AGAINST OVERLOAD	38
2.5.6	PROTECTION OF GENERATORS	38
2.5.7	AUTOMATIC LOAD SHEDDING	39
2.5.8	PROTECTION OF POWER AND LIGHTING TRANSFORMERS	40
2.5.9	PROTECTION OF FEEDER CIRCUITS	40
2.5.10	PROTECTION OF MOTORS	41
2.5.11	PROTECTION OF LIGHTING CIRCUITS	41
2.5.12	PROTECTION OF STORAGE BATTERIES	42
2.5.13	PROTECTION OF METERS, PILOT LAMPS AND CONTROL CIRCUITS	42
2.5.14	POWER ELECTRONIC DEVICES	42
2.6	AUXILIARY MECHANISMS	42
2.6.1	GENERAL REQUIREMENTS	42
2.6.2	STEERING GEAR	43
2.6.3	PERMANENTLY INSTALLED SUBMERSIBLE BILGE PUMPS	43
2.6.4	DECK MACHINERY	44

2.6.5	FIRE EXTINGUISHING SYSTEMS	44
2.6.6	EMERGENCY STOPS FOR VENTILATING FANS AND OIL PUMPS	44
2.7	LIGHTING AND NAVIGATION LIGHTS	45
2.7.1	GENERAL REQUIREMENTS	45
2.7.2	SUPPLY AND CONTROL FOR LIGHTING CIRCUITS	45
2.7.3	EMERGENCY LIGHTING	47
2.7.4	NAVIGATION LIGHTS	48
2.8	INTERNAL, COMMUNICATION SYSTEMS	48
2.8.1	MAIN ENGINE TELEGRAPH SYSTEM	48
2.8.2	IMPORTANT TELEPHONE SYSTEM	49
2.8.3	COMMUNICATIONS IN AN EMERGENCY	49
2.8.4	ALARMS FOR ENGINEERS	50
2.9	SAFETY SYSTEM FOR SHIPS AND PERSONS ONEWARD	50
2.9.1	GENERAL EMERGENCY ALARMS	50
2.9.2	PUBLIC ADDRESS SYSTEM	51
2.9.3	PRE-DISCHARGE ALARMS OF 6RE EXTINGUISHING SYSTEMS	51
2.9.4	ELEVATOR ALARMS	52
2.9.5	CLOSING ALARM FOR REFRIGERATED SPACES	52
2.9.6	FIREDETECTIONAND6REALANNSYSTEMS	52
2.9.7	FIRE-PROTECTION DOORS	52

2.9.8	WATERTIGHT DOORS IN PASSENGER SHIPS	52
2.9.9	WATERTIGHT ACCESS DOORS AND HATCH COVERS, ETC. IN CARGO SHIPS OF 80 M OR ABOVE IN LENGTH	54
2.9.10	BOW DOORS, STERN DOORS, SHELL DOORS, LOADING DOORS AND OTHER CLOSING APPLIANCES IN RO-RO PASSENGER SHIPS	54
2.10	HEATING AND COOKING EQUIPMENT	55
2.10.1	GENERAL REQUIREMENTS	55
2.10.2	CONTROL AND INSTALLATION OF HEATING AND COOKING EQUIPMENT	55
2.10.3	SUPPLY OF HEATING EQUIPMENT	55
2.11	STORAGE BATERIES	56
2.11.1	ARRANGEMENT AND INSTALLATION	56
2.11.2	VENTILATION	56
2.11.3	CHARGING FACILITIES	57
2.11.4	ELECTRICAL EQUIPMENT	58
2.12	CABLES	59
2.12.1	GENERAL REQUIREMENTS	59
2.12.2	CHOICE OF INSULATING MATERIAL	59
2.12.3	CHOICE OF PROTECTIVE COVERING	60
2.12.4	DETERMINATION OF THE CROSS-SECTIONAL AREA OF CONDUCTOR	61
2.12.5	CONTINUOUS SERVICE CURRENT RATING	61
2.12.6	CORRECTION FACTORS FOR CURRENT RATING	63



2.12.7	PARALLEL CONNECTION OF CABLES	65
2.12.8	SHORT-CIRCUIT CAPACITY	66
2.12.9	CABLE RUNS	66
2.12.10	MEASURES TO LIMIT THE PROPAGATION OF FIRE ALONG CABLE AND WIRE BUNDLES	67
2.12.11	MECHANICAL PROTECTION OF CABLES	69
2.12.12	RADIUS OF BEND	69
2.12.13	SECURING OF CABLES	70
2.12.14	PENETRATION OF BULKHEADS AND DECKS BY CABLES	71
2.12.15	INSTALLATION OF CABLES IN PIPES, CONDUITS OR TRUNKING	71
2.12.16	INSTALLATION OF CABLES IN REFRIGERATED SPACES	72
2.12.17	RELIEF OF TENSION	73
2.12.18	ELECTRODYNAMIC FORCES	73
2.12.19	INSTALLATION OF SINGLE-CORE CABLES FOR ALTERNATING CURRENT	73
2.12.20	CABLES INSTALLATION WITH RESPECT TO PREVENTION OF ELECTROMAGNETIC INTERFACE	74
2.12.21	EARTHING OF METAL SHEATHINGS OR COVERINGS	74
2.12.22	CABLE ENDS	74
2.12.23	JOINTS AND TAPPINGS	75
2.12.24	JOINT BOXES	75
2.12.25	CABLE TRAYS/PROTECTIVE CASINGS MADE OF PLASTICS MATERIALS	75



2.13	LIGHTNING CONDUCTORS	76
2.13.1	PROTECTION AGAINST PRIMARY STRUCTURAL DAMAGE	76
2.13.2	PROTECTION AGAINST SECONDARY DAMAGE	77
2.14	SPECIAL REQUIREMENTS FOR HIGH VOLTAGE ELECTRICAL INSTALLATIONS	78
2.14.1	GENERAL REQUIREMENTS	78
2.14.2	SYSTEM DESIGN	78
2.14.3	ROTATING MACHINERY	80
2.14.4	POWER TRANSFORMERS	81
2.14.5	CABLES	81
2.14.6	SWITCHGEAR AND CONTROLGEAR ASSEMBLIES	81
2.14.7	INSTALLATION	82
2.15	ADDITIONAL REQUIREMENTS FOR ELECTRICAL PROPULSION INSTALLATIONS	83
2.15.1	GENERAL REQUIREMENTS	83
2.15.2	PRIME MOVERS	84
2.15.3	ROTATING MACHINES	84
2.15.4	EXCITATION	85
2.15.5	CONTROLGEAR	86
2.15.6	CABLES	87
2.15.7	MAIN CIRCUITS	87
2.15.8	PROTECTION	87



2.15.9	INSTRUMENTATION	88
2.16	ADDITIONAL REQUIREMENTS FOR OIL TANKERS	89
2.16.1	GENERAL REQUIREMENTS	89
2.16.2	ELECTRICAL EQUIPMENT IN DANGEROUS ZONES OR SPACES OF OIL TANKERS CARRYING CARGO OILS HAVING A FLASH POINT NOT EXCEEDING 60 °C.	92
2.16.3	OTHER REQUIREMENTS FOR OIL TANKERS CARRYING CARGO OILS HAVING A FLASH POINT NOT EXCEEDING 60 °C	93
2.16.4	OIL TANKERS CARRYING CARGO OILS HAVING A FLASHPOINT EXCEEDING 60°C AND NOT HEATED OR HEATED TO THE TEMPERATURE MORE THAN 15 °C BELOW ITS FLASHPOINT.	94
2.16.5	OIL TANKERS CARRYING CARGO OILS HAVING A FLASHPOINT EXCEEDING 60°C AND HEATED ABOVE ITS FLASHPOINT OR HEATED TO THE TEMPERATURE LESS THAN 15°C OF ITS FLASHPOINT	94
2.17	ADDITIONAL REQUIREMENTS FOR SHIPS CARRYING VEHICLES WITH FUEL IN THEIR TANKS FOR THEIR OWN PROPULSION	95
2.17.1	GENERAL REQUIREMENTS	95
2.17.2	IN PASSENGER SHIPS WITH SPECIAL CATEGORY SPACES ABOVE THE BULKHEAD DECK AND CLOSED RO-RO CARGO SPACES OF CARGO SHIP'S (TO GIVE LESS THAN 10 AIR CHANGES PER HOUR) FOR CARRYING VEHICLES.	95
2.17.3	IN PASSENGER SHIPS WITH SPECIAL CATEGORY SPACES BELOW THE BULKHEAD DECK AND CLOSED RO-RO CARGO SPACES OF CARGO SHIPS (TO GIVE LESS THAN 10 AIR CHANGES PER HOUR) FOR CARRYING VEHICLES	95
2.17.4	IN PASSENGER SHIP WITH RO-RO CARGO SPACES AND CARGO SPACES OTHER THAN SPECIAL CATEGORY SPACES FOR CARRYING VEHICLES	95
2.17.5	IN CARGO SPACES OF CARGO SHIPS FOR CARRYING VEHICLES	95
2.17.6	IN PASSENGER SHIPS AND WEATHER DECK SPACES CARRYING VEHICLES	96

2.18	ADDITIONAL REQUIREMENTS FOR SHIPS CARRYING DANGEROUS GOODS	96
2.18.1	GENERAL REQUIREMENTS	96
2.18.2	CARRIAGE OF EXPLOSIVE SUBSTANCES IN PACKAGED FORM, CONFORMING TO CLASS 1, REQUIRED IN 2.18.1.2(1)	97
2.18.3	CARRIAGE OF SOLID DANGEROUS GOODS IN BULK WHICH MAY DEVELOP DANGEROUS DUST ONLY	98
2.18.4	CARRIAGE OF FLAMMABLE LIQUIDS WITH A FLASH POINT BELOW 23°C IN PACKAGED FORM, FLAMMABLE GASES AND HIGHLY DANGEROUS BULK CARGOES WHICH, UNDER CERTAIN CONDITIONS, DEVELOP A POTENTIALLY EXPLOSIVE GASEOUS ATMOSPHERE.	98
2.18.5	SPECIAL REQUIREMENTS	101
2.18.6	INSTALLATION OF ELECTRICAL SYSTEM IN HAZARDOUS AREAS	101
2.18.7	PORTABLE ELECTRICAL EQUIPMENT IN HAZARDOUS AREAS	102
2.18.8	MISCELLANEOUS	102
 CHAPTER 3: SPARE PARTS		
3.1	GENERAL REQUIREMENTS	103
3.1.1	GENERAL REQUIREMENTS	103
3.2	PROVISION OF SPARE PARTS	103
3.2.1	ELECTRICAL MACHINERY	103
3.2.2	PROVISION OF ELECTRIC APPLIANCES	103
 CHAPTER 4: CONSTRUCTION AND TESTING OF ELECTRICAL EQUIPMENT		
4.1	ROTATING MACHINES	104



4.1.1	GENERAL REQUIREMENTS	104
4.1.2	TEMPERATURE RISE	105
4.1.3	SPARKING	108
4.1.4	OVERLOADS	108
4.1.5	SHORT-CIRCUITS	108
4.1.6	D.C. GENERATORS	109
4.1.7	A.C. GENERATING SETS	110
4.1.8	TESTING	111
4.2	SWITCHGEAR ASSEMBLIES	113
4.2.1	DESIGN AND CONSTRUCTION OF SWITCHGEAR ASSEMBLIES	113
4.2.2	BUS-BARS	115
4.2.3	MEASURING INSTRUMENTS	116
4.2.4	CIRCUIT BREAKERS AND SWITCHES	117
4.2.5	FUSES	118
4.2.6	TESTING	118
4.3	CONTROL GEAR	119
4.3.1	GENERAL REQUIREMENTS	119
4.3.2	MOTOR CONTROL GEAR	120
4.3.3	TESTING	120
4.4	CABLES	121



4.4.1	GENERAL REQUIREMENTS	121
4.4.2	CONDUCTORS	121
4.4.3	INSULATING MATERIALS	121
4.4.4	INSULATION	122
4.4.5	CONSTRUCTION	122
4.4.6	SHEATHS AND PROTECTIVE COVERINGS	122
4.4.7	TESTING	123
4.5	POWER AND LIGHTING TRANSFORMERS	124
4.5.1	GENERAL REQUIREMENTS	124
4.5.2	VOLTAGE REGULATION	124
4.5.3	PARALLEL OPERATION	124
4.5.4	TEMPERATURE RISE	124
4.5.5	SHORT-CIRCUITS	125
4.5.6	TESTS	125
4.6	STORAGE BATERIES	126
4.6.1	GENERAL REQUIREMENTS	126
4.6.2	TYPE	126
4.6.3	CONSTRUCTION	126
4.6.4	NAMEPLATE	127
4.7	POWER SEMICONDUCTOR CONVERTORS	127



4.7.1	GENERAL REQUIREMENTS	127
4.7.2	PROTECTION	127
4.7.3	TESTING	128
4.8	OTHER ELECTRICAL EQUIPMENT	129
4.8.1	INCANDESCENT LIGHTING	129
4.8.2	DISCHARGE LAMP LUMINAIRES OPERATING AT VOLTAGES BELOW 250 V	129
4.8.3	DISCHARGE LAMP LUMINAIRES OPERATING AT VOLTAGES ABOVE 250 V	130
4.8.4	NAVIGATION LIGHTS AND OTHER SIGNAL LIGHTS	130
4.8.5	HEATING AND COOKING APPLIANCES	130
4.8.6	ACCESSORIES	132
CHAPTER 5: SUPPLEMENTARY REQUIREMENTS FOR SMALL SHIPS AND SHIPS IN RESTRICTED SERVICE		
5.1	GENERAL REQUIREMENTS	132
5.1.1	GENERAL REQUIREMENTS	132
5.2	SHIPS ENGAGED ON NON-INTERNATIONAL VOYAGES AND IN COASTAL AND GREATER COASTAL SERVICES	133
5.2.1	EARTH INDICATOR	133
5.2.2	MAIN SOURCE OF ELECTRICAL POWER	133
5.2.3	EMERGENCY SOURCE OF ELECTRICAL POWER	133
5.2.4	SPARE POWER SOURCES	134
5.2.5	LIGHTING	134



5.2.6	STEERING GEAR	134
5.2.7	APPLICATION OF FIRE-RETARDANT CABLES	134
5.3	SHIPS NAVIGATING IN SHELTERED WATER SERVICE	135
5.3.1	GENERAL REQUIREMENTS	135
5.3.2	MAIN SOURCE OF ELECTRICAL POWER	135
5.3.3	RESERVE SOURCE	135
5.3.4	SUPPLY OF CONTROL BOX FOR NAVIGATION LIGHTS	135
5.4	CARGO SHIPS OF LESS THAN 500 GROSS TONNAGE	135
5.4.1	GENERAL REQUIREMENTS	135
5.4.2	DISTRIBUTION SYSTEMS	136
5.4.3	RESERVE SOURCE	136
5.4.4	CONTROL AND SUPPLY OF NAVIGATION LIGHTS	136
5.4.5	ALARM SYSTEM	136

CHAPTER 1 GENERAL PROVISIONS

1.1 GENERAL REQUIREMENTS

1.1.1 General requirements

1.1.1.1 The requirements of this PART apply, unless otherwise specified, to electrical installations intended for classed passenger ships and cargo ships.

1.1.1.2 Whilst these requirements are considered to meet those of the SOLAS Convention in force, attention is also to be given to any relevant statutory regulations of the Administration of the flag States in which the ship is to be registered.

1.1.1.3 Electrical propelling machinery and associated equipment together with auxiliary services essential for the safety of the ship are to be constructed and installed in accordance with the relevant requirements of this PART and are to be inspected and tested by the Surveyors. In addition, construction and testing of the electrical equipment are to comply with the relevant standards recognized by the Society.

1.1.1.4 The design and installation of the equipment other than those specified in 1.1.1.3 is to be such that risk of fire due to its failure is minimized, and it is at least to comply with a recognized standard to be revised where necessary for ambient conditions.

1.1.1.5 In addition, the electrical installations are to comply with the requirements as appropriate in GENERAL and PART ONE of the Rules.

1.1.1.6 The electrical installations are to be such that:

- a. All electrical services necessary for maintaining the ship in normal and operational and habitable conditions will be assured without recourse to the emergency source of power;
- b. Electrical services essential for safety will be assured under various emergency conditions;
- c. The safety of passenger, crew and ship from electrical hazards will be assured.

1.1.2 Definitions

1.1.2.1 For the purpose of this PART:

- 1) Essential equipment is the equipment necessary for the propulsion, maneuverability, navigation and safety of the ship and the type-specific equipment on ships with special class notation, including:
 - Primary essential equipment is that which need to be in continuous operation for the ship's maneuverability with regard to propulsion and steering e.g. :

- a. Steering;

- b. Controllable pitch propeller installation;
- c. Charging air blowers, fuel feeder pumps, fuel booster pumps, lubricating oil pumps and fresh cooling water pumps for main and auxiliary engines and turbines, so far as required for propulsion;
- d. Forced draught fans, feed water pumps, water circulating pumps, condensate pumps and oil burning installation for min- and auxiliary steam boilers for the operation of primary essential equipment;
- e. Azimuth thrusters which are the sole means for propulsion/steering with lubricating oil pumps, cooling water pumps;
- f. Electrical equipment for electric propulsion plant with lubricating oil pumps and cooling water pumps;
- g. Electric generators and associated power sources supplying the equipment mentioned in (a) to (f);
- h. Hydraulic pumps supplying the mentioned in (a) to (f);
- i. Viscosity control equipment for heavy oil;
- j. Control, monitoring and safety devices/systems for equipment mentioned in (a) to (i);

- Secondary essential equipment is that which need not necessarily be in continuous operation for maintaining for the ship's maneuverability and steering, but which are necessary for maintaining the ship's safety, e.g:

- a. Windlasses;
- b. Fuel oil transfer pumps and fuel oil treatment equipment;
- c. Lubricating oil transfer pumps and lubricating oil treatment equipment;
- d. Pre-heaters for heavy fuel oil;
- e. Starting air and control air compressors;
- f. Bilge, ballast and heeling pumps;
- g. Fire pumps and other fire extinguishing medium pumps;
- h. Ventilating fans for engine and boiler rooms;
- i. Necessary equipment to maintain the safety in dangerous spaces;
- j. Navigational lights, aids and signals;
- k. Internal communication equipment required in this PART;
- l. Fire detection and alarm system;
- m. Main lighting system;
- n. Watertight closing appliances;
- o. Electric generators and associated power sources supplying the equipment mentioned in (a) to (n);
- p. Hydraulic pumps supplying the equipment mentioned in (a) to (n);
- q. Control, monitoring and safety systems for cargo containment systems;
- r. Control, monitoring and safety devices/systems for equipment mentioned in (a) to (p);

- In the case of ships with a special class notation which may be classified as essential equipment.
- 2) Non-essential equipment is that whose temporary disconnection does not impair propulsion and steerability of the ship and does not endanger the safety of passenger, crew, cargo, ship and machinery.
- 3) Emergency consumer is a mandatory consumer which, after breakdown of the main energy supply, must be fed by the emergency energy supply.
- 4) Main source of electrical power is a source intended to supply electrical power to the main switchboard for distribution to all services necessary for maintaining the ship in normal operational and habitable condition.
- 5) Emergency source of electrical power is a source of electrical power, intended to supply the emergency switchboard in the event of failure of the supply from the main source of electrical power.
- 6) Dead ship condition means a condition under which the main propulsion plant, boilers and auxiliaries are not in operation and in restoring the propulsion, no stored energy for starting the propulsion plant, the main source of electrical power and other essential auxiliaries is to be assumed available.
- 7) Primary distribution system is a system having electrical connection with the generator.
- 8) Secondary distribution system is a system having no electrical connection with the generator, e.g. isolated therefrom by a double-wound transformer.
- 9) Low—voltage system is a system operating with the maximum rated voltage not exceeding 1000 V inclusive and with rated frequencies of 50 HZ or 60 Hz, or direct-current system where the maximum instantaneous value of the voltage under rated operating conditions does not exceed 1500 V.
- 10) High-voltage system is a system operating with the rated voltage more than 1 kV but not exceeding 15 kV and with rated frequencies of 50 Hz or 60 Hz or direct-current system where the maximum instantaneous value of the voltage under rated operating conditions exceed 1500 V.
- 11) Switch gear and control gear assembly is one or more switch gear together with control, measurement, signal, protection and adjustment, etc. and the assembled by the internal connection, and structural members of all the electrical and machinery installations fitted by the manufacturers.
- 12) Main switchboard is a switchboard which is directly supplied by the main source of electrical power and is intended to distribute and control the electrical energy to the assembly of switch gears and control gears of the ship's services.
- 13) Emergency switchboard is a switchboard which in the normal conditions is supplied by the main switchboard but in the event of failure of the main electrical power supply system is directly supplied by the emergency source of electrical power or the transitional source of emergency power and is intended to distribute and control the electrical energy to the assembly of switch gears and control gears of the ship's emergency services.
- 14) Distribution board is an assembly arranged for the control and distribution of electrical power to final sub-circuits.

- 15) Final sub-circuit is that portion of a wiring system extending beyond the final overcurrent device of a board.
- 16) Total discrimination is an overcurrent discrimination where in the presence of two or more overcurrent protection devices in series, the protective device on the load side effects the protection without causing the other protective devices to operate.
- 17) Partial discrimination is an overcurrent discrimination where, in the presence of two or more overcurrent protective devices in series, the protective device closest to the fault effects the protection up to a given level of short-circuit current without causing the other protective devices to operate.
- 18) Back-up protection is the protection equipment or system which is intended to operate when a system fault is not cleared in due time because of failure or inability of a protective device closest to the fault to operate.
- 19) Continuity of service is the condition that during and after a fault in a circuit, the supply to the healthy circuits is permanently ensured.
- 20) Dangerous space is space where flammable or explosive vapour, gas or dust, or explosives may be normally expected to accumulate.
- 21) Enclosed space is a space sheltered by bulkhead and deck with doors, windows or other openings which may be opened or closed.
- 22) Semi-enclosed space is a space limited by top plate, wind break and bulkhead, etc. in such a manner that the natural conditions of ventilation in the space are notably different from those obtained on weather deck and the gas is uneasily diffuse.
- 23) A blackout situation means that the main and auxiliary machinery installations, including the main power supply, are out of operation but the services for bringing them into operation (e.g. compressed air, starting current from batteries etc.) are available.

1.1.3 Plans and documents

1.1.3.1 The following required plans and documents are to be submitted to the Society for approval:

- a. Electrical loading calculations of main and emergency sources of electrical power;
- b. Calculations for short-circuit currents (for ships whose generator capacity is more than 250 kVA);
- c. Analysis for coordination of protective electrical installations in compliance with the requirements of 2.5.1.1 and 2.5.4.1, so far as practicable;
- d. Diagrams of main switchboard, in which the following are to be marked:
 - Type, specifications and setting of the protective electrical installations (such as short-circuit, overloading, reverse power and unloading protection);
 - Measuring instrument;
 - Synchronizing device;
 - Remote cut;
 - Earthing breakdown monitoring and alarm;

- Interlock;
- e. Diagrams of emergency switchboard (or emergency battery charging and discharging board) , in which the following are to be marked:
- Type, specifications and setting of the protective electrical installations (such as short-circuit, overloading protection);
 - Measuring instrument;
 - Earthing breakdown monitoring and alarm;
 - Interlock;
- f. Diagrams of power system, in which the following are to be marked:
- Main rating of motors, transformers, batteries and electrical power and electronic equipment;
 - All feeders from main and emergency switchboards;
 - Section board (if fitted) and distribution board;
 - Type, cross-section and current of cables;
 - Type and main rating of breakers and fuses;
- g. Arrangement of electrical power equipment, in which the position of the following installations are to be marked:
- Main and emergency generators;
 - Main and emergency switchboards (or emergency accumulator battery and discharging board);
 - Emergency accumulator battery;
 - Electrical equipment for essential services (see 1.1.2.1);
- h. Schematic diagrams of main.
- i. Arrangement of main lighting;
- j. Schematic of emergency and temporary emergency lighting;
- k. Arrangement of emergency lighting and temporary emergency lighting;
- l. Schematic diagrams of internal communication system, including:
- Telegraph system;
 - Essential telephone system;
 - Communication system for life-saving;
 - Engineers alarm system;
- m. Arrangement of internal communication system, including:
- Telegraph system;

- Essential telephone system;
 - Communication system for life-saving;
 - Engineers alarm system;
- n. Schematic diagrams of safety system for ships and persons on board, including:
- General emergency alarm system;
 - Public address system;
 - Fire detection and fire alarm system;
 - Watertight doors closing alarm;
 - Pre-warnings for the release of extinguishing media (see 2.9);
- o. Arrangement of safety system for ships and persons on board, including:
- General emergency alarm system;
 - Public address system;
 - Fire detection and fire alarm system;
 - Watertight doors closing alarm;
 - Pre-warnings for the release of extinguishing media (see 2.9);
- p. Arrangement of main cable runs (for passenger ships and high voltage electrical installations);
- q. General arrangement of the ship showing dangerous zones and spaces (for oil tankers and other ships carrying dangerous explosive goods);
- r. Diagram of electrical propulsion installations, in which the following are to be marked:
- Main rating of motors, transformers, batteries and electrical power and electrical equipment;
 - Type, cross-section and current of cables;
 - Type and main rating of breakers and fuses;
 - Earthing breakdown monitoring and alarm;
 - Explanations according to the requirements in 2.15;
- s. Arrangement for control panel of electrical propulsion installations

1.1.3.2 The specifications for electrical part onboard are to be submitted to the Society for information.

1.1.3.3 Additional plans and documents may be required if considered necessary by the Society.

1.1.3.4 The electrical equipment manufacturers are to additionally submit the related plans and documents for approval as required in the Society.

1.1.4 Testing

1.1.4.1 Electrical equipment specified in 1.1.1.3 and 1.1.2.1 (1) is to be tested in accordance with the relevant requirements of Chapter 4 at the manufacturer’s works. Tests other than those specified in this PART may be required when the Society deems necessary.

1.1.4.2 On completion of installation on board, the electrical installations are to be subject to mooring and sea trials in accordance with the test programmes approved by the Society.

1.2 OPERATING CONDITIONS

1.2.1 Environmental conditions

1.2.1.1 Unless otherwise specified, all electrical equipment are to operate satisfactorily under the following environmental conditions:

- a. The ambient air temperatures and primary cooling water temperatures areas given in Table 1.2.1.1(1), but the upper limit of ambient air temperature for the electrical equipment is to be 55 C;
- b. The inclination of ships from the normal is as given in Table 1.2.1.1(2);
- c. The vibration and shock likely to arise under normal service of ships;
- d. Moisture, sea air, oil vapours and mould.

Table 1.2.1.1 (1)
Ambient Temperatures

Medium	Location	Temperature (C)	
		Unrestricted service	Restricted service except navigation in the tropical zone
Air	In enclosed spaces	0 ~ 45	0 ~ 40
	In spaces subject to temperatures 45 °C more (40 °C) and below 0 °C	According to specific local conditions	According to specific local conditions
	On the open deck	-25 ~ 45	25 ~ 40
Seawater		32	25

Table 1.2.1.1 (2)
Angle of inclination

Equipment, components	Angle (°) ① ②			
	Athwartships		Fore-and-aft	
	Static	Dyn	Static	Dyn
Emergency electrical installations, switchgear, electrical and electronic appliances	22.5	22.5	10	10
Electrical Installations excluding items stated above	15	22.5	5	7.5

Note: ① Athwartships and Fore-and-aft inclinations may occur simultaneously

② For ships carrying liquefied gases or carrying chemicals, the emergency source of electrical power on board is to be capable of keeping the supply when the ship is inclined at an angle of final list up to 30 ° of the limit due to the ships flooding.

1.2.2 Voltage and frequency fluctuations

1.2.2.1 Electrical equipment is to operate satisfactorily under the voltage and frequency fluctuations as given in Table 1.2.2.1

1.2.3 Harmonics content

1.2.3.1 A.C. electrical equipment is to operate satisfactorily under the harmonics content of distribution systems not exceeding 5% in relation to the peak value of the sinusoidal fundamental. When supplied by static converters, it is to operate satisfactorily under harmonics content which may exceed 5%.

Table 1.2.2.1
Voltage and frequency fluctuations

Equipment	Parameters	Permanent (%)	Transient	
			%	Max. recovery time (s)
General	Voltage	+6 ~ -10	±20	1.5
	Frequency	±5	± 10	5
Equipment supplied by accumulator batteries: connected to batteries during charging not connected to the batteries during charging	Voltage	+30 ~ -25	-	-
	Voltage	+20 ~ -25	-	-

1.3 DESIGN, CONSTRUCTION AND INSTALLATION

1.3.1 General requirements

1.3.1.1 Electrical equipment is to be so designed, constructed and installed as to ensure safe operation and provide facility for inspection and repair.

1.3.1.2 The distance between live parts of different potential and between live parts and earthed metal, whether across surfaces or in air, is to be adequate for the working voltage having regard to the nature of the insulating material and the conditions of service.

1.3.1.3 Equipment is not to remain alive through the control circuits or pilot lamps when switched off by the control switch. This does not apply to synchronizing switches and/or plugs.

1.3.1.4 All nuts and screws used for the connection and fastening of electrical equipment are to be effectively locked so that they cannot work loose by vibration.

1.3.1.5 The material which is used to make electrical equipment is to comply with the following requirements:

- a. It is, in general, to be durable, flame-retardant, moisture resistant unless it is adequately protected in the atmospheres and the temperatures to which it is likely to be exposed;
- b. Materials and insulated windings are to be resistant to moisture, sea-air and oil vapour unless special precautions are taken to protect insulants against such agencies;
- c. The current carrying parts of electrical equipment are, in general, to be made of copper or copper alloys;
- d. Metal parts of electrical equipment are to be covered with proper protective coating against corrosion unless they are made of satisfactory corrosion-resistant material.

1.3.1.6 If electrical fittings, not of aluminium, are connected to aluminium, suitable means is to be taken to prevent electrolytic corrosion.

1.3.1.7 All electrical equipment with internal wiring is to be attached with schematic or wiring diagrams marked with circuit designations. All terminals of electrical equipment are to be provided with durable labels or identification marks corresponding to those indicated in the diagrams.

1.3.1.8 The controls for emergency alarms are to be marked in red colour and to be provided with durable nameplates indicating their purposes.

1.3.1.9 Rheostats, starting and charging resistors, heating appliances and other apparatus likely to cause high temperatures are to be so placed or provided with suitable means that they will not cause excessive heat to adjacent materials or a risk of fire.

1.3.1.10 All electrical equipment is not to be in direct contact with the surfaces of oil , oil tanks or double bottom tanks intended for carrying oils. If necessary, electrical equipment is to be installed at a minimum distance of 50 mm from these surfaces, but the electrical apparatus mentioned in 1.3.1.9 is strictly prohibited to be installed in such a manner.

1.3.1.11 All generating sets are to be installed with their shafts in parallel with the fore-and-aft line of the ship, and all horizontal motors are also to be installed, as far as practicable, with their shafts in parallel with the fore-and-aft line of the ship.

1.3.1.12 For all electrical equipment having a working voltage or a voltage to earth exceeding 50 V, other than those installed in a separate compartment, the live parts are to be so protected that they cannot be in advertently touched.

1.3.1.13 Where the temperature of the enclosures of the electrical equipment is in excess of 80°C, suitable means are to be provided or suitable arrangement is to be made so as to protect the operators from being burnt due to in advertent touching.

1.3.1.14 Holes are not to be drilled in watertight bulkheads, decks or boundary plating of deckhouses for the purpose of fitting the securing screws for the electrical equipment and cables.

1.3.1.15 Electrical equipment and cables are not to be fitted on the shell plating.

1.3.1.16 Conductors and equipment are to be placed at a distance from the compass, or are to be so screened that the interfering external magnetic field is negligible.

1.3.2 Type of protective enclosures

1.3.2.1 The type of protective enclosures for electrical equipment is to comply with the relevant standards accepted by the Society.

The designation to indicate the degrees of protection consists of the characteristic letters IP followed by two numerals as follows:

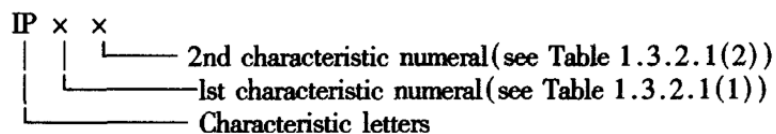

Table 1.3.2.1 (1)
Degrees of protection indicated by the first characteristic numeral

First characteristic numeral	Degree of protection	
	Brief description	Definition
0	Non protected	No special protection
1	Protected against solid objects greater than 50 mm	A large surface of the body, such as a hand (but no protection against deliberate access). Solid objects exceeding 50 mm in diameter
2	Protected against solid objects greater than 20mm	Fingers or similar objects not exceeding 80mm in length. Solid objects exceeding 12mm in diameter
3	Protected against solid objects greater than 20mm	Tools, wires, etc. of dia or thickness greater than 2.5mm in diameter
4	Protected against solid objects greater than 20mm	Wires or strips of thickness greater than 1 mm. Solid object exceeding 1 mm in diameter
5	Dust – protected	Ingress of dust is not totally prevented, but dust does not enter in sufficient quantity to interfere with satisfactory operation of the equipment
6	Dust- light	No ingress of dust

Table 1.3.2.1 (2)
Degrees of protection indicated by the second characteristic numeral

First characteristic numeral	Degree of protection	
	Brief description	Definition
0	Non- Protected	No special protection
1	Protected against dripping water	Dripping water(vertically falling drops) is to have no harmful effect
2	Protected against dripping water when tilted water up to 15°	Vertically dripping is to have no harmful effect when the enclosure is tilted at any angle up to 15° from its normal position
3	Protected against spraying water	Water falling as a spray at an angle up to 60° from the vertical is to have no harmful effect
4	Protected against spashing water	Water splashed against the enclosure from any direction is to have no harmful effect
5	Protected against water jets	Water projected by a nozzle against the enclosure from any direction is to have no harmful effect
6	Protected against heavy seas	Water from heavy seas or water projected in powerful jets is not to enter the enclosure in harmful quantities
7	Protected against the effects of immersion	Ingress of water in a harmful quantity is not be possible when the enclosure is immersed in water under defined conditions of pressure and time
8	Protected against submersion	The equipment is suitable for continuous submersion in water under conditions which is to be specified by the manufacturer Note: Normally, this will mean that the equipment is hermetically sealed. However, with certain types of equipment, it can mean that water can enter but only in such a manner that produces on harmful effects

1.3.2.2 The type of protective enclosures selected for electrical equipment is to be appropriate to the conditions of the location at which such equipment is installed. The lowest degree of protection is to comply with the requirements given in Table 1.3.2.2.

Table 1.3.2.2
Minimum requirements for the degree of protection (4)

1	2	3	4								
			Equipment								
Location	Condition in location	Design according to degree of protection	Switchboards control gear motor starters	Generators	Motors	Transformers semiconductor converters	luminaires	Heating appliances	Cooking appliances	Accessories eg switches branch boxes	
Dry accommodation spaces	Danger of touching live parts only	IP20	x	-	x	x	x	x	x	x	
Dry control rooms			x	-	x	x	x	x	x	x	
Control rooms	Danger of dripping water and/or moderate mechanical damage	IP22	x	-	x	x	x	x	x	x	
Engine and boiler room above floor			x	X	x	x	x	x	x	IP44	
Steering gear rooms			x	X	x	x	x	x	x	IP44	
Refrigerating machinery rooms (excluding ammonia plants)			x	-	x	x	x	x	x	-	IP44
Emergency machinery rooms			x	x	x	x	x	x	x	-	IP44
General storage rooms			x	-	x	x	x	x	x	-	x
Pantries			x	-	x	x	x	x	x	-	IP44
Provision rooms			x	-	x	x	x	x	x	-	x

1	2	3	4							
			Equipment							
Location	Condition in location	Design according to degree of protection	Switchboards control gear motor starters	Generators	Motors	Transformers semiconductor converters	luminaires	Heating appliances	Cooking appliances	Accessories eg switches branch boxes
Bathroom and showers	Increased danger of water and/or mechanical damage	IP34	-	-	-	-	x	IP44	-	IP55
Engine and boiler room below floor			-	-	IP44	-	x	IP44	-	IP55
Closed fuel oil separator room			IP44	-	IP44	-	x	IP44	-	IP55
Closed lub-oil separator room			IP44	-	IP44	-	x	IP44	-	IP55
Ballast pump rooms	Increased danger of water and mechanical damage	IP44	x	-	x	x	IP34	x	-	IP55
Refrigerating rooms			-	-	x	-	IP34	x	-	IP55
Galleys and laundries			X	-	x	x	IP34	x	X	x
Shaft or pipe tunnels in double bottom	Danger of water spraying. Presence of cargo dust. Serious mechanical damage. Aggressive fumes	IP55	X	-	x	x	x	x	-	IP56
Holds for general cargo			-	-	-	-	x	-	-	x
Open decks	Danger of water in massive quantities	IP56	X	-	x	-	IP55	x	-	x

Notes: ① In the table, X means that the requirements of column (3) are to be complied with, or if impossible, the requirements of note ② are to be satisfied; “-” means that the requirement of column (3) are generally not recommended.

② Where the protection is not achieved by the equipment itself, other means or the improvement of installations condition is to ensure the degree of protection required in the table.

③ Where electrical equipment is installed in areas where explosive dusts may be present, it is to comply with the requirements of 1.3.3.7.

④ Where the main and emergency switchboards are constructed and installed in accordance with the requirements of 4.2, 2.2 and 2.1, the requirements of this table may be dispensed with.

1.3.3 Explosion protection

1.3.3.1 Where electrical equipment is installed in areas where explosive gas or vapour atmospheres may be present, it is to be of a certified safe type complying with the following requirements:

- a. The construction and type testing of safe type electrical equipment is to be in accordance with the relevant standards accepted by the Society.
- b. The safe type electrical equipment is to be certified by a competent testing authority by the Society.

1.3.3.2 Certified safe type equipment normally used on board ships includes the following types of protection:

- a. Intrinsically safe Ex "i";
- b. Flameproof Ex "d";
- c. Increased safety Ex "e";
- d. Pressurized enclosure Ex "p";
- e. Powder " filling Ex "q";
- f. Encapsulation Ex "m".

1.3.3.3 The electrical equipment allowed to be fitted in spaces subject to explosion hazard, e.g. battery rooms, lamp rooms and paint stores (including ventilation ducts) is to comply with the following requirements:

- a. The group and temperature class of certified safe type equipment listed in 1.3.3.2 are to at least comply with the requirements in Table 1.3.3.3;
- b. Cables (through-runs or terminating cables) of armoured type or installed in metallic conduits are to be used;
- c. The switches, protective devices and motor control gear for the equipment installed in such spaces are to interrupt all poles or phases and preferably are to be located in non-hazardous spaces.

For additional requirements of paint store ventilation openings, battery rooms, oil tankers and ships with spaces for carrying vehicles with fuel in their tanks for their own propulsion, see 1.3.3.4, 1.3.3.5 and 2.11, 2.16 and 2.17.

Table 1.3.3.3
The group and temperature class

Location	Group ^①	Temperature class ^①
Battery rooms	II C ^②	T1
Paint stores	II B	T3
Lamp rooms	II A	T3
Ammonia plant rooms	II A	T1
Stores for welding –gas bottles	II C	T2
Holds classified as hazardous	According to the mode of carriage of dangerous goods	According to the mode of carriage of dangerous goods
Tunnels for pipes containing oil with a flashpoint of 60°C or below	II A	T3

Notes: ①The group and temperature class of certified safe type equipment listed in this Table and herein after in this part is according to the relevant requirements of IEC Publication 60079: Electrical Apparatus for Explosive Gas Atmospheres or equivalent standards, e.g. GB3836. Electrical apparatus for explosive atmospheres.

②Groups II A, II B and II C of certified safe type equipment specified in this part are applicable only to intrinsically safe apparatus and flameproof apparatus. When other types of certified safe type equipment are used. Group II is accepted.

1.3.3.4 In the case on weather deck within 1 m of inlet and exhaust ventilation openings or within 3 m of exhaust mechanical ventilation outlets, the following electrical equipment may be installed:

- a. Safety type equipment and cables specified in 1.3.3.3;
- b. Equipment of protection class Ex "n";
- c. Appliances which do not generate arcs in service and whose surface does not reach unacceptably high temperature;
- d. Appliances with simplified pressurized enclosures or vapour-proof enclosures (minimum class of protection IP55) whose surface does not reach unacceptably high temperature.

1.3.3.5 The enclosed spaces giving access to the paint store may be considered as non-hazardous, provided that:

- a. The door to the paint store or the door of the store is a gastight door with self-closing devices (a watertight door may be regarded as a gastight door) without holding back arrangements;
- b. The paint store is provided with an acceptable, independent, natural ventilation system ventilated from a safe area;



- c. Warning notices are fitted adjacent to the paint store entrance stating that the store contains flammable liquids.

1.3.3.6 Socket outlets are, unless expressly specified otherwise, not to be installed in spaces subject to explosion hazard.

1.3.3.7 Where electrical equipment is installed in areas where explosive dusts may be deposited, it is to comply with the following requirements:

- a. Degree of protection is to be at least IP55;
- b. The maximum surface temperature of the equipment in continuous service is to be at least 75 K lower than the glow temperature of a 5 mm thick layer of the dust.

1.3.4 Earthing

1.3.4.1 All accessible metal parts of electrical equipment, other than current-carrying accessible pans, are to be earthed unless:

- a. Lamp caps;
- b. Shades, reflectors and guards, supported on lampholders or lighting fittings constructed of, or shrouded in, non-conducting material;
- c. Metal parts on, or screws in or through, non-conducting material, which are separated by such material from current-carrying parts, and from earthed non-current-carrying parts, in such a way that in normal use they cannot become live or come into contact with earthed pans;
- d. Portable appliances having double and/or reinforced insulation, provided that the appliances conform with recognized safety requirements;
- e. Bearing housings which are insulated in order to prevent circulation of current in the bearings;
- f. Clips for fluorescent lighting tubes;
- g. Apparatus supplied working voltage not more than 50 V. For A.C. , this voltage is a value of root mean square between conductors. Auto-transformers are not to be used for the purpose of achieving this voltage;
- h. Cable clips.

1.3.4.2 When the electrical equipment is directly fixed on the ships metal structures or securely fixed on bedplates (or supports) which have a good electrical contact with ships metal structures, a special earthing conductor may not be required.

1.3.4.3 Whether the earthing is achieved through a special conductor or by the equipment bedplates (or supports), the surfaces in contact are to be clean, flat and bright so as to ensure an effective contact, and measures are to be taken to prevent the connection from loosening and corrosion.

1.3.4.4 When special earthing conductors are used, they are to be of copper or other corrosion-resistant materials of good conductivity, and are to be protected against mechanical damage and corrosion where necessary. The nominal cross-sectional area of every copper earthing conductor is not to be less than required in Table 1.3.4.4.

Table 1.3.4.4
Sizes of earthing conductors

Type of earthing conductor	Cross-sectional area of associated Current-carrying conductor S(mm)	Minimum cross-sectional area of copper earthing conductor Q (mm)
Earthing- continuity conductor in flexible cable or flexible cord	$S < 16$	$Q = S$
	$S > 16$	$Q = S/2$, but a least 16
Earthing- continuity conductor in flexible cable or flexible cord	$S < 16$	$Q = S/2$, but a least 1.5
	$S > 16$	$Q = S/2$, but a least 16
Special fixed earthing conductor	$S < 2.5$	$Q = S/2$, but a least 1.5
	$2.5 < S < 120$	$Q = S/2$, but a least 4
	$S < 120$	$Q = 70$

1.3.4.5 Metal pans of movable or portable appliances, other than the current-carrying pans, are to be earthed means of an earth-continuity conductor in the flexible cable or cord, which is earthed through the associated plug and socket outlet, and the cross-sectional area of the earth conductor is to comply with the requirements of Table 1.3.4.4.

1.3.4.6 Metal sheathings or coverings of cables are to be effectively earthed at both ends of the cable, except in final sub-circuits where earthing at the supply end only will be considered adequate. This does not necessarily apply to control and instrumentation cables where single point earthing may be desirable for technical reasons.

1.3.4.7 The metal sheathings or coverings of cables are to be earthed by one of the means described below:

- a. Grippled by metal clamps and connected to the metal hull of the ship by copper earthing conductors. The relationship between the cross-sectional area Q of the copper earthing conductors and the cross-sectional area S of the current-carrying conductors of the cables is to be as follows:

$$Q \geq 1.5 \text{ mm}^2, \quad \text{when } S \leq 25 \text{ mm}^2;$$

$$Q \geq 4 \text{ mm}^2, \quad \text{when } S > 25 \text{ mm}^2;$$

- b. By means of glands intended for this purpose and so designed as to ensure an effective earth connection;
- c. To be earthed by means of clamps or clips of corrosion-resistant metalmarking effective contact with the sheaths or coverings of cables and earthed metal.

1.3.4.8 The electrical continuity of all metal sheathings or covering of cables throughout the length of the cable, particularly at joints and tapings, is to be ensured.

1.3.4.9 The lead sheath of lead-sheathed cables is not to be used as the sole means of earthing the non-current carrying parts of items of equipment.

1.3.4.10 Every connection of an earth-continuity conductor or a special earthing conductor to the ships structure is to be made in an accessible position, and is to be secured by a screw of brass or other corrosion-resistant material of a diameter not less than 4mm which is to be used for this purpose only.

1.3.4.11 Where aluminium, superstructures are secured to the steel hull of a ship with a insulation to prevent electrolytic corrosion between these materials, a separate bonding connection is to be provided between the superstructure and the hull which is to be made in such a manner that electrolytic corrosion is avoided and the connection points may readily be inspected.

1.3.4.12 Bonding straps are required for cargo tanks process plant and piping systems, for flammable products, which are not permanently connected to the hull of the ship either directly or via their bolted or welded supports and where the resistance between them and the hull exceeds $1 \text{ M}\Omega$. Such bonding straps are to be made of copper or other corrosion-resistant materials of good conductivity, but having a cross-sectional area of at least 10 mm^2 . The connection with the hull is to comply with the requirements of 1.3.4.3 and 1.3.4.10.

1.3.5 Electromagnetic compatibility

1.3.5.1 Appropriate measures are to be taken to reduce the interference due to electromagnetic energy, so that all electrical and electronic equipment can operate normally in a ship's electromagnetic environment.

1.3.5.2 The allowable value of the voltage (current) of the interference induced by electrical and electronic equipment and the means of interference suppression are to comply with the relevant provisions of the Standards accepted by the Society.

1.3.6 Visual and acoustical signal

1.3.6.1 Except those required in 1.3.6.2, the colour code for visual signal is to comply with the requirements of Table 1.3.6.1.

1.3.6.2 Except those required above, the visual and acoustical signals are to comply with the requirements of regulations or standards accepted by the Society.

Table 1.3.6.1
Colour code of visual signal

Colour	Meaning	Explanation	Example
Red	Danger or alarm	Warning of danger or a situation which requires immediate action	Operation failure of essential equipment; temp.or pressure of water/oil to a critical value; Power failure of essential circuits
Yellow	Caution	Change or impending change of conditions	Temp. or pressure is abnormal but not to a critical value
Green	Safety (Normal operation and normal working conditions)	Indication of a safe situation	Normal operation of machinery; Normal circulation of liquids; Pressure. Temp. and current, etc is within the limited value
Blue	Instruction/information (specific meaning assigned according to the need in the case considered	Blue may be given meaning which is not covered by the three above colours: red, yellow and green	Motor begins to start; Unloading generator begins to switch on; Heating circuit of stopping motor is connected
White	No specific meaning assigned	Any meaning, it can be used if considered red, yellow and green is not applicable	Earthing insulation indication; synchroscope Telephone calling; Equipment by automatic control

CHAPTER 2: ELECTRICAL INSTALLATIONS IN SHIPS

2.1 MAIN SOURCE OF ELECTRICAL POWER

2.1.1 Generating sets

2.1.1.1 A main source of electrical power of sufficient capacity to supply all the services mentioned in 1.1.1.6(a) is to be provided, and the following requirements are to be complied with:

- a. This main source of electrical power is to consist of at least two generating sets, but for small ships navigating in the restricted service and special case, due consideration may be given subject to agreement of the Society.
- b. The number and ratings of these generating sets are to be such that in the event of any one generating set being stopped it will still be possible to supply those services necessary to provide normal operational conditions of propulsion and safety of the ship, and essential for the preservation of cargo in ships classed for carrying refrigerated cargoes (see Volume FIVE for ships with class notation for carrying refrigerated cargoes). Furthermore, minimum comfortable conditions of habitability are also to be ensured which include at least adequate services for cooking, heating, domestic refrigeration, mechanical ventilation, sanitary and fresh water.
- c. In addition, the generating sets are to be such as to ensure that with any one generator or its primary source of power out of operation, the remaining generating sets are to be capable of providing the electrical services necessary to start the main propulsion plant from a dead ship condition.
- d. Where the main source of electrical power is necessary for propulsion and steering of the ship, the continuity of the power supply to the equipment necessary for the propulsion and steering and for ensuring the safety of the ship is to comply with the following requirements:
 - Where the electrical power is normally supplied by more than one generator set simultaneously in parallel operation, provision of protection, including automatic disconnection (see 2.5.7.1) of sufficient non-essential services and if necessary secondary essential services and those provided for habitability, are to be made to ensure that, in case of loss of any of these generating sets, the remaining ones are kept in operation to permit propulsion and steering and the equipment necessary for ensuring the safety of the ship.
 - Where the electrical power is normally supplied by one generator provision is to be made, upon loss of power, for automatic starting and connecting to the main switchboard of stand-by generators of sufficient capacity with automatic restarting of the essential auxiliaries, in sequential operation if required. Starting and connection to the main switchboard of one generator is to be as rapid as possible, preferably within 30s after loss of power.
 - Where prime movers with longer starting time are used, this starting and connection time may be exceeded subject to approval by the Society.
- e. Where the main source of electrical power is necessary for propulsion of the ship, the main bus-bar is to be subdivided into at least two parts which are normally connected by circuit breakers or

other approved means so far as is practicable, the connection of generating sets and other duplicated equipment are to be equally divided between the parts.

- f. A public electric power plant both for main source of electrical power and electrical power for propulsion may be provided, which is to comply with the requirements of 2.15.1.6.

2.1.1.2 In alternating current systems with one generating set out of action, the remaining sets are to have sufficient reserve capacity to permit the starting of the largest motor in the ship without causing any motor to stall or any other devices to fail due to excessive voltage drop on the system. Motors with very large capacity, such as side thruster motors, not essential to the safe navigation of the ship may be started when all generators are put into operating conditions, but it is not to cause any essential equipment out of action.

2.1.1.3 The arrangements of the ship's main source of electrical power are to be such that the services referred to in 1.1.1.6(a) can be maintained regardless of the speed and direction of rotation of the propulsion machinery or shafting.

2.1.2 Generators driven by main propulsion machinery (shaft-driven generators)

2.1.2.1 Generators and generator systems, having the ship's main propulsion machinery as their prime mover, may be accepted as part of the ship's main source of electrical power, provided:

- a. They are to be capable of operating under all weather conditions during sailing and during maneuvering, also when the vessel is stopped, within the specified limits for the voltage variation in paragraphs 4.1.6, 4.1.7 and the frequency variation in 1.2.2.1;
- b. Their rated capacity is in compliance with 2.1.1.1(b) in the event of any other one of the generators failing;
- c. The short circuit current of the generator/generator system is sufficient to trip the generator/generator system circuit-breaker taking into account the selectivity of the protective devices for the distribution system. Protection is to be arranged in order to safeguard the generator/generator system in case of a short circuit in the main bus bar. The generator/generator system is to be suitable for further use after fault clearance.
- d. Standby sets are started in compliance with 2.1.1.1(d).

2.1.2.2 Generators and generator systems, having the ship's propulsion machinery as their prime mover but not forming part of the ship's main source of electrical power may be used whilst the ship is at sea to supply electrical services required for normal operational and habitable conditions provided that:

- a. There are sufficient and adequately rated additional generators fitted, which constitute the main source of electrical power required by 2.1.1.1;
- b. Arrangements are fitted to automatically start one or more of the generators in compliance with 2.1.1.1(d);
- c. The limits for voltage variations specified in paragraphs 4.1.6, 4.1.7 can be met and the frequency variations are within $\pm 10\%$ of the limits specified in 1.2.2.1;

- d. The short circuit current of the generator and/or generator system is sufficient to trip the generator/generator system circuit-breaker taking into account the selectivity of the protective devices for the distribution system;
- e. Automatic load shedding arrangements are fitted to meet the requirements of 2.5.7;
- f. On ships having remote control of the ship's propulsion machinery from the navigation bridge means are provided, or procedures be in place, so as to ensure that supplies to essential services are maintained during maneuvering conditions in order to avoid a blackout situation.

2.1.3 Transformers

2.1.3.1 The number, capacity and arrangement of power transformers are to meet the following requirements if they constitute the necessary parts of main electric power source system as required in 2.1.1.1:

- a. The power transformers are to be such that when any one of them is out of operation, the remaining transformer(s) is (are) sufficient to ensure the safe operation of those services necessary to provide normal operational conditions of propulsion, safety, and the minimum comfortable conditions of habitability are also to be ensured, which include at least adequate services for cooking, heating, domestic refrigeration, mechanical ventilation, sanitary and fresh water.
- b. Each transformer required is to be located as a separate unit with separate enclosure or equivalent, and is to be served by separate circuits on the primary and secondary sides.
- c. Each primary circuit is to be provided with switch-gear and protection devices in each phase.
- d. Each of the secondary circuits is to be provided with a multi-pole isolating switch.

2.1.4 Installation of switchboard

2.1.4.1 The main switchboard is to be so placed relative to one main generating station that, as far as is practicable, the integrity of the normal electrical supply may be affected only by a fire or other casualty in one space. An environmental enclosure for the main switchboard, such as may be provided by a machinery control room situated within the main boundaries of the space, is not to be considered as separating the switchboards from the generators.

2.1.4.2 Water, oil or steam pipes, oil tanks or other liquid containers are not to be installed above or behind the switchboards, if they are unavoidable, suitable protection is to be provided in these positions.

2.1.4.3 An ample space is to be left in front and at the rear of switchboards, at least 0.8 m wide in the front and at least 0.6 m wide at the rear. If the construction of switchboards is such as to permit maintenance, inspection and replacement of parts both from the front side and from the ends, passageways behind switchboards may be dispensed with.

2.1.4.4 Except that main switchboards are installed in machinery control room, a door with lock is to be provided at the access to the passageway behind switchboards. Where the length of switchboard is greater than 4 m, access doors are to be provided at both ends of the passageway behind switchboards.

2.1.4.5 Non-slipping and oil-proof non-conducting mats or grating of impregnated wood are to be fitted in front and at the rear of the main switchboard.

2.2 EMERGENCY SOURCE OF ELECTRICAL POWER

2.2.1 General requirements

2.2.1.1 All passenger ships and cargo ships of more than 500 gross tonnages are to be provided with a self-contained emergency source of electrical power.

2.2.1.2 The emergency source of electrical power is to be so arranged as to comply with the following:

- a. The emergency source of electrical power associated transforming equipment, if any, transitional source of emergency power, emergency switchboard and emergency lighting switchboard are to be located above the uppermost continuous deck and is to be readily accessible from the weather deck. They are not to be located forward of the collision bulkhead, except where permitted by the Society for cargo ships in exceptional circumstance.
- b. The location of the emergency source of electrical power, associated transforming equipment, if any, the transitional source of emergency power, the emergency switchboard and emergency electric lighting switchboard in relation to the main source of electrical power, associated transforming equipment, if any, and the main switchboard is to be to the satisfaction of the Society, so as to ensure that a fire or other casualty in spaces containing the main source of electrical power, associated transforming equipment, if any, and the main switchboard, or in any machinery space of category A will not interfere with the supply, control and distribution of emergency electrical power. As far as practicable, the space containing the emergency source of electrical power, associated transforming equipment, if any, the transitional source of emergency electrical power and the emergency switchboard is not to be continuous to the boundaries of machinery spaces of category A or those spaces containing the main source of electrical power, associated transforming equipment, if any, or the main switchboard.

2.2.1.3 The emergency source of electrical power may be a generator, which is to comply with the following requirements:

- a. Driven by a suitable prime-mover with an independent supply of fuel and cooling, and with an accessory starting arrangements complying with the requirements of these regulations;
- b. Started automatically upon failure of the main source of electrical power supply and connected automatically to the emergency switchboard, unless for cargo ships a transitional source of emergency electrical power in accordance with 2.2.1.5 is provided. And those services referred to in 2.2.2.2 (for passenger ships) or 2.2.3.2 (for cargo ships) are then to be transferred automatically to

the emergency generating set. The automatic starting system and the characteristics of the prime-mover are to be such as to permit the emergency generator to carry its full rated load as quickly as is safe and practicable, subject to a maximum of 45s.

2.2.1.4 The emergency source of electrical power may also be an accumulator battery, which is to be capable of:

- a. Carrying the emergency electrical load without recharging while maintaining the voltage of the battery throughout the discharge period within $\pm 12\%$ above or below its nominal voltage;
- b. Automatically connecting to the emergency switchboard in the event of failure of the main source of electrical power;
- c. Supplying those services (except as otherwise stated) specified in 2.2.2.1 (for passenger ships) or 2.2.3.1 (for cargo ships), and immediately supplying at least those services specified in 2.2.2.2 (for passenger ships), or 2.2.3.2 (for cargo ships).

2.2.1.5 Where the emergency source of electrical power is a generator, a transitional source of emergency electrical power which consists of an accumulator battery is to be provided, unless for cargo ships where an automatically started emergency generator in accordance with 2.2.1.3 (b) is provided. The transitional source of emergency electrical power is to comply with the following requirements:

- a. It can operate without recharging while maintaining the voltage of the battery throughout the discharge period within $\pm 12\%$ above or below its nominal voltage and be of sufficient capacity;
- b. It is so arranged as to supply automatically in the event of failure of either the main or emergency source of electrical power at least those services referred to in 2.2.2.2 (for passenger ships) or 2.2.3.2 (for cargo ships).

2.2.1.6 Where electrical power is necessary to restore propulsion, the capacity is to be sufficient to restore propulsion to the ship in conjunction with other machinery, as appropriate, from a dead ship condition within 30 min after blackout.

2.2.1.7 The emergency switchboard is to be installed as near as is practicable to the emergency source of electrical power and to comply with the following requirements:

- a. Where the emergency source of electrical power is a generator, the emergency switchboard is to be located in the same space unless the operation of the emergency switchboard would thereby be impaired;
- b. Where the emergency source of electrical power is an accumulator battery, the accumulator battery is not to be installed in the same space as the emergency switchboard;
- c. The spaces in front and at the rear of the emergency switchboard, etc. are to comply with the requirements given in 2.1.4.2 to 2.1.4.5.

2.2.1.8 An indicator is to be mounted in a suitable place on the main switchboard or in the machinery control room to indicate when the batteries constituting either the emergency source of electrical power or transitional source of emergency electrical power are being discharged.

2.2.1.9 The emergency switchboard is to be supplied during normal operation from the main switchboard by an interconnector feeder which is to be adequately protected at the main switchboard according to the requirements of 2.5.9.6 and which is to be disconnected automatically at the emergency switchboard upon failure of the main source of electrical power.

2.2.1.10 In order to ensure ready availability of the emergency source of electrical power, arrangements are to be made where necessary to disconnect automatically non-emergency circuits from the emergency switchboard to ensure that electrical power is to be available to the emergency circuits.

2.2.1.11 Provided that suitable measures are taken for safeguarding independent emergency operation under all circumstances, the emergency generator may be used exceptionally, and for short periods, to supply non-emergency circuits.

2.2.2 Scope and period of supply of the emergency source in passenger ships

2.2.2.1 The electrical power available is to be sufficient to supply all those services that are essential for safety in an emergency, due regard being paid to such services as may have to be operated simultaneously. The emergency source of electrical power is to be capable, having regard to starting currents and the transitory nature of certain loads, of supplying simultaneously at least the following services for the periods specified hereinafter, if they depend upon an electrical source for their operation:

- a. For a period of 36 h, emergency lighting:
 1. at every muster and embarkation station on deck and over the sides as required in the SOLAS Convention in force;
 2. In alleyways, stairways and exits giving access to the muster and embarkation stations as required in the SOLAS Convention in force;
 3. In all escape routes with their stairways and exits (including angles and intersections) placed not more than 0.3 m above the deck as required in the SOLAS Convention in force (where emergency source is required for the supply) ;
 4. In all services and accommodation alleyways, stairways and exits, personnel lift cars;
 5. In public spaces and in cabins accommodating more than 16 persons;
 6. in the machinery spaces and main generating stations including their control positions;
 7. in all control stations, machinery control rooms, and at each main and emergency switchboard;
 8. At all stowage positions for firemen's outfits;
 9. At the steering gear;
 10. At the fire pump, the sprinkler pump and the emergency bilge pump and at the Starting position of their motors.

- b. For a period of 36 h:
 1. The navigation lights and other signal lights required in International Regulations for Preventing Collisions at Sea in force;

2. VHF radio equipment, MF radio equipment (if any) , ship earth station (if any) and MF/HF radio equipment (if any) required in the SOLAS Convention in force.
- c. For a period of 36 h:
1. All internal communication equipment required in an emergency;
 2. The navigational aids as required in the SOLAS Convention in force, where such provision is unreasonable or impracticable, this requirement for ships of less than 5 000 gross tonnage may be waived, subject to agreement of the Society;
 3. The fire detection and fire alarm system, and the fire door holding and release system;
 4. For intermittent operation of the daylight signalling lamp, the ships whistle, the manually operated call points and all internal signals that are required in an emergency (e . g. general alarms, pre-warnings for the release of extinguishing media, etc.) . Unless such services mentioned above in ① to ④ have an independent supply for the period of 36 hours from an accumulator battery suitably located for use in an emergency.
- d. For a period of 36 h:
1. One of the fire pumps required in SOLAS;
 2. The automatic sprinkler pump, if any;
 3. The emergency bilge pump and all the equipment essential for the operation of electrically powered remote controlled bilge valves.
- e. For the period of time required in these regulations, the steering gear if required to be so supplied.
- f. For a period of half an hour:
1. Any watertight doors required in the SOLAS Convention in force to be power operated together with their indicators and warning signals;
 2. The emergency arrangements to bring the lift cars to deck level for the escape of persons. The passenger lift cars may be brought to deck level sequentially in an emergency.
- g. For ships have a class notation of coastal service and are engaged regularly in voyages of short duration where the mute is not greater than 20 n miles off shore, where it is regarded to be the same safety by the Society, the power supply period less than 36 h required in (a) to (d) could be considered, but not less than 12h.

2.2.2.2 To be transitional source of emergency electrical power required in 2.2.1.5 is to be of sufficient capacity to supply at least the following services, if they depend upon an electrical source for their operation:

- a. For half an hour:
1. The lighting required in 2.2.2.1 (a) and navigation lights and other signal lights required in 2.2.2.1(b) ①;

2. All services required in 2.2.2.1 (c) ①, ③ and ④ unless 1 such services have an independent supply for the period specified from an accumulator battery suitably located for use in an emergency.
- b. Power to operate the watertight doors but not necessarily all of them simultaneously, unless an independent temporary source of stored energy is provided.
 - c. Power to the control, indication and alarm circuits for operation of watertight doors for half an hour.
- 2.2.2.3 In addition to the emergency lighting required above, on every passenger ship with m-m cargo spaces or special category spaces:
- a. All public passenger spaces and alleyways are to be provided with supplementary emergency lighting complying with the following:
 - 1. CD to be capable of operating for at least three hours when all other sources of electrical power have failed and under any condition of heel;
 - 2. The illumination provided is to be such that the approach to the means of escape can be readily seen;
 - 3. The source of power for the supplementary lighting is to consist of accumulator batteries located within the lighting units that are continuously charged, where practicable, from the emergency switch-board. Alternatively, any other means of lighting which is at least as effective may be accepted by the Society;
 - 4. The supplementary lighting is to be such that any failure of the lamp will be immediately apparent;
 - 5. Any accumulator battery provided is to be replaced at intervals having regard to the specified service life in the ambient conditions that they are subject to in service;
 - b. A portable rechargeable battery operated lamp is to be provided in every crew space alleyway, recreational space and every working space which is normally occupied unless supplementary emergency lighting, as required in (a) above, is provided.

2.2.3 Scope and period of supply of the emergency source in cargo ships

2.2.3.1 The electrical power available is to be sufficient to supply all those services that are essential for safety in an emergency, due regard being paid to such services as may have to be operated simultaneously. The emergency source of electrical power is to be capable, having regard to starting currents and the transitory nature of certain loads, of supplying simultaneously at least the following services for the periods specified hereinafter, if they depend upon an electrical source for their operation:

- a. For a period of 3 h, emergency lighting at every muster and embarkation station and over the sides as required in the SOLAS Convention in force.

- b. For a period of 18 h, emergency lighting:
1. In all services and accommodation alleyways, stairways and exits, personnel lift cars and personnel lift trunks;
 2. In the machinery spaces and main generating stations including their control positions;
 3. In all control stations, machinery control rooms, and at each main and emergency switchboard;
 4. At all stowage positions for firemen's outfits;
 5. at the steering gear;
 6. At the tire pump referred to in (e) above, at the sprinkler pump, if any, and at the emergency bilge pump, if any, and at the starting positions of their motors.
- c. For a period of 18 h:
1. The navigation lights and other signal lights required in International Regulations for Preventing Collisions at Sea in force;
 2. VHF radio equipment, MF radio equipment (if any) , ship earth station (if any) and MF/HF radio equipment (if any) required in the SOLAS Convention in force.
- d. For a period of 18 h:
1. All internal communication equipment as required in an emergency;
 2. The navigational aids as required in the SOLAS Convention in force, where such provision is unreasonable or impracticable, this requirement for ships of less than 5 000 gross tonnage may be waived, subject to agreement of the Society;
 3. The fire detection and fire alarm system;
 4. Intermittent operation of the daylight signalling lamp, the ships whistle, the manually operated call points and all internal signals that are required in an emergency (e. g. general alarms, pre-warnings for the release of extinguishing media, etc.) .
- Unless such services mentioned above in ① to ④ have an independent supply for the period of 18 hours from an accumulator battery suitably located for use in an emergency.
- e. For a period of 18 h, one of the fire pumps required in PART SIX if dependent upon the emergency generator for its source of power.
- f. For the period of time required in these regulations, the steering gear where it is required to be so supplied.
- g. For ships have a class notation of coastal service and are engaged regularly in voyages of short duration where the mute is not greater than 20 n miles off shore, where it is regarded to be the same safety by the Society, the power supply period less than 18 h required in (b) to (e) could be considered, but not less than 12h.

2.2.3.2 The transitional source of emergency electrical power required in 2.2.1.5 is to be of sufficient capacity to supply at least the following services for half an hour, if they depend upon an electrical source for their operation:

- a. The lighting required in 2.2.3.1(a) and (b), and navigation lights and other signal lights required in 2.2.3.1(c) ①. For this transitional phase, the required emergency electric lighting, in respect of the machinery space and accommodation and service spaces may be provided by permanently fixed, individual, automatically charged, relay operated accumulator lamps;
- b. All services required in 2.2.3.1 (d) ①, ③ and ④, unless such services have an independent supply for the period specified from an accumulator battery suitably located for use in an emergency.

2.3 EXTERNAL POWER SOURCE

2.3.1 Shore supply

2.3.1.1 Where arrangements are made for the supply of electricity from a source on shore or elsewhere, a suitable connection box complying with the requirements of 4.2.1.12 is to be installed in a position in the ship suitable for the convenient reception of flexible cables from the external source. Suitable cables having adequate ratings, permanently fixed, are to be provided for connection between the shore connection box and the main switchboard.

2.3.1.2 When three phase A. C. distribution system with neutral earthed is adopted for shore and/or ship supply, an earth terminal is to be provided for connecting the ship's hull to the shore earth. In case of D. C. systems with hull return, the negative terminal of the shore supply must be connected to hull.

2.3.1.3 The shore connection is to be provided with an indicator at the main switchboard in order to show when the cable is energized.

2.4 POWER SUPPLY AND DISTRIBUTION

2.4.1 Power supply and distribution systems

2.4.1.1 The following systems of distribution may be used:

- a. D.C.
 - Two -wire insulated system;
 - Two- wire system with negative pole earthed;
 - Single- wire systems with negative to hull return.
- b. A.C. single phase
 - Two-wire insulated system;
 - Two-wire system with one pole earthed;
 - Single - wire system with hull return.

c. Three phase A.C.

Three-wire insulated system;

Four-wire system with neutral earthed;

Three-wire system with neutral earthed and the hull serving as neutral wire.

Other distribution systems than those mentioned above are to be subject to special approval by the Society.

2.4.1.2 For power supply and distribution systems for high-voltage system, Refer to the requirements of 2.14.2.1.

2.4.1.3 For ships intended for the carriage of crude oil and petroleum products in bulk having a flashpoint (closed cup test) below 60°C, the distribution systems are to comply with the requirements of 2.16.1.1.

2.4.2 Insulation distribution system

2.4.2.1 The neutral of generating sets are not to be connected together in the insulation distribution system.

2.4.2.2 The insulated distribution systems for power, heating and lighting, whether primary or secondary, are to be provided with a device capable of continuously monitoring the insulation level to earth and of giving an audible and visual indication of abnormally low insulation values.

2.4.3 Earthed and hull return system of distribution

2.4.3.1 The hull return system of distribution is not to be used for power, heating or lighting in ships of 1600 gross tonnage and upwards, but not excluding the following conditions:

- a. Impressed current cathodic protective systems;
- b. Limited and locally earthed systems, if current so produced will not pass through any hazardous areas;
- c. Insulation level monitoring devices provided the circulation current does not exceed 30 mA under the most unfavorable conditions.

2.4.3.2 Where hull return systems are used, all final sub-circuits are to have all-pole or phase insulation, the return conductors are to be connected in the associated distribution switchboard to an insulated busbar, which is connected to the hull.

2.4.3.3 The earthing distribution in high-voltage system is to be in compliance with the relevant requirements of 2.14.2.1.

2.4.3.4 The service earthing conductors used in the hull return system are to be of the same cross-sectional area as the conductors in the insulated pole or phase.

2.4.3.5 Casing or their mounting bolts are not to be used as return conductors or to make their connection.

2.4.3.6 The cross-sectional area of service earthing conductors which do not normally carry current is to be 50% of that of the current-carrying conductors, but not less than 1.5 mm².

2.4.3.7 The system earthing of earthed distribution systems is to be effected by means independent of any earthing arrangements of non-current-carrying parts of the electrical equipment.

2.4.4 Voltage and frequency

2.4.4.1 except those specially permitted by the Society, the maximum voltages of D. C. or A. C. Distribution systems are not to exceed the values given in Table 2.4.4.1.

**Table 2.4.4.1
Maximum voltages of distribution system**

	Application	Max. voltage (V)
1	For power equipment permanently installed, connected to fixed wiring	15000
2	(1) For power, heating and cooking equipment permanently installed, connected to fixed wiring, except space heater in accommodation spaces (2) For power and heating equipment (other than space heater in accommodation spaces) permanently installed where connection by flexible cable is necessary because of the application, e.g. movable cranes etc. (3) For portable equipment, which is not hand- held during operation, connected by socket – outlet and flexible cable which incorporates an earth continuity conductor of a size in accordance with 1.3.4.5. E.g. welding transformer	1000
3	(1) For lighting and heaters in accommodation and public spaces (2) For socket- outlets supplying the following types of portable apparatus: 1. with double insulation 2. earthed by means of an earth-continuity conductor of a size in accordance with 1.3.4.5 of this PART	250
4	For socket. outlets supplying portable apparatus used in spaces where particular risks due to conductivity may exist, e.g. exceptionally damp or confined spaces: (1) supplied or not supplied or not supplied form an isolating- transformer (2) supplied from a safety isolating- transformer supplying one consuming apparatus only, the two wires of those socket out –lets are to be insulated to earth	50 250

Note: for the control voltage of distribution systems above 500 V, see the requirements of 2.4.4.2.

2.4.4.2 For distribution systems above 500 V the control voltage is to be limited to 250 V, except when all control devices of the distribution system are enclosed in the related control box and the distribution voltage is not higher than 1 000 V.

2.4.4.3 The standard frequency for A. C. Distribution systems is to be 50 Hz or 60 Hz.

2.4.5 Balance of loads

2.4.5.1 For A. C. Three-wire or four-wire systems, the current-consuming units are to be so grouped in the final sub-circuits that the load on each phase will, under normal conditions, be balanced as far as possible within 15% of their respective rated load at the individual distribution and section boards as well as the main switchboard.

2.4.6 Diversity factors

2.4.6.1 Circuits supplying two or more final sub-circuits are to be rated in accordance with the total connected load subject, where justified, to the application of a diversity factor. Where spare ways are provided on a section or distribution board, an allowance for future increase of load is to be added to the total connected load before application of any diversity factor.

2.4.6.2 The diversity factor may be applied to the calculation of the cross-sectional area of conductors and rating of Switchgear and fuse gear.

2.4.6.3 For cargo winches, a diversity factor may be applied based on the information available from the manufacturer and the information agreed upon between manufacturer and purchaser. If there is no information available, the diversity factors of Table 2.4.6.3 may be applied.

Table 2.4.6.3
Diversity factors

Number of motors	Current to be provided for	
	Cases in which motors are of the same size	Cases in which motors are of different sizes
2	100% of combined full-load of motors	
3	67% of combined full-load of motors	100% of full-load of the largest motor + 50% of full-load of each one of the other motors
4	62% of combined full-load of motors	
5	60% of combined full-load of motors	
6 or more	58% of combined full-load of motors	

2.4.6.4 For the diversity factors of socket circuits for refrigerated containers, refer to the requirements of these regulations.

2.4.7 Power supply to essential equipment

2.4.7.1 Unless expressly provided otherwise, the primary essential equipment is to be supplied directly from the main or emergency switchboard (if any), exempt for the total discrimination.

2.4.8 Power supply to radio equipment and navigation equipment

2.4.8.1 The power supply to radio equipment as required in Chapter IV of the SOLAS Convention (hereinafter called radio equipment) and electrical/electronic navigation equipment as required in Chapter V of the SOLAS Convention (hereinafter called the navigation equipment) are to comply with the requirements of 2.4.8.2 to 2.4.8.6.

2.4.8.2 The distribution board of supplies to navigation equipment is to be independent of those for radio equipment. Where radio equipment requires an uninterrupted input of information from the ship's navigation equipment or other equipment, it will be necessary for the equipment providing the data to be supplied from the same distribution board serving the radio equipment.

2.4.8.3 The distribution board of radio equipment and that of navigation equipment supplied by emergency electrical source are to be supplied by the feeders of main and emergency switchboard and each distribution board is to be provided with changing-over device which can be initiated automatically .

2.4.8.4 Failure of any power supply to the distribution board required in 2.4.8.3 is to initiate an audible and visual alarm at the navigation bridge.

2.4.8.5 Each consumer is to be supplied by independent final sub-circuit from distribution board individually.

2.4.8.6 A reserve source or sources independent from ship's propulsion and electric system is to be provided to supply radio equipment for the purpose of conducting distress and safety radio communications, in the event of failure of the ship's main or emergency sources of electrical power. The capacity of the reserve source or sources is to be capable of supplying to the following equipment simultaneously for 1 h:

- a. VHF radio equipment;
- b. MF radio equipment or ship earth station or MF/HF radio equipment;
- c. Suitable illuminations of radio control console for operating radio equipment.



2.4.9 Power supply to auxiliary machinery motors, etc.

2.4.9.1 In addition to the above-mentioned requirements, the power supply to auxiliary machinery motors, illuminations, navigation a light, internal communication system and safety system of ships and persons on board is to comply with the relevant requirements of this PART.

2.4.10 Sockets

2.4.10.1 The sockets of general portable devices are to be in compliance with the requirements of No. 3 and No. 4 in Table 2.4.4.1.

2.4.10.2 For the sockets of distribution systems with different voltages and/or frequencies, non-interchangeable plug and socket connections are to be used.

2.4.10.3 No plug-in connections are to be provided in the enclosed fuel-lubrication oil separator mom below the floor in the machinery spaces.

2.4. 10.4 Sockets in cargo holds may be installed only in positions with sufficient protection against mechanical damage.

2.4.10.5 For sockets of refrigerated containers, refer to the relevant requirements of these regulations.

2.5 PROTECTION

2.5.1 General requirements

2.5.1.1 Electrical installations are to be protected against accidental overcurrent and other electric fault, including short-circuits by appropriate devices. Choice, arrangement and performance of the protective devices are to provide complete and coordinated automatic protection in order to ensure:

- a. Continuity of service through the discriminative action of the protective devices to maintain supply to healthy circuits, especially to the healthy circuits of essential equipment, in the event of a fault elsewhere;
- b. Elimination of the effect of faults to reduce damage to the system and the hazard of fire as much as possible.

2.5.1.2 Short-circuit protection is to be provided in each non-earthed pole (or phase) in the distribution systems.

2.5.1.3 Overload protection is to be provided in:

- a. Two-wire D. C. or single-phase A. C. System - at least one pole or phase;

- b. Insulated three-phase A. C. system - at least two phases;
- c. Earthed system - each non-earthed pole or phase.

2.5.1.4 No fuse or non-linked switch is to be inserted in an earthed conductor in the distribution systems.

2.5.2 Calculations of short-circuit current

2.5.2.1 In the calculation of the maximum prospective short-circuit current; consideration is to be given to:

- a. The number of generators which are normally simultaneously connected in parallel to satisfy the maximum required power;
- b. The maximum number of motors which are normally simultaneously connected in the system.

2.5.2.2 When necessary, the prospective short-circuit power factor of the A. C. system is to be calculated. If the short-circuit power factor so obtained is less than the short-circuit power factor corresponding to the rated short-circuit making or breaking capacity of the selected switching gear, then the breaking capacity of such a switching gear is to be reduced accordingly.

2.5.2.3 Short-circuit calculations are to be performed in accordance with the Society's Guidance Notes: Short-circuit Calculations of A. C. Electrical System for Ships and Offshore Installations, or other methods accepted by the Society.

2.5.2.4 In general, short-circuit calculations are to be carried out by assuming the points of fault at the following locations:

- a. At the output terminal of generators;
- b. At the main bus-bar;
- c. At the bus-bars of the emergency switchboard, section switchboards and distribution switchboards;
- d. At the secondary side of power and lighting transformers. For the evaluation of the discrimination of the system, the minimum short-circuit current at the end of feeders is also to be calculated, if necessary, when only the smallest generator is in supply.

2.5.3 Choice of protective devices against short-circuit

2.5.3.1 Protection against short-circuit currents is to be provided by circuit-breakers or fuses.

2.5.3.2 Unless otherwise specified in 2.5.3.3 and 2.5.3.5, the breaking capacity of protective devices against short-circuit is to comply with the following requirements:

- a. The rated short-circuit breaking capacity of circuit breakers and general fuses is not to be less than the maximum prospective short-circuit current at the point of installation. For the A. C. systems, the rated short-circuit breaking capacity is not to be less than the prospective symmetrical short-circuit current (root-mean-square value) at the point of installation;

- b. The rated operating short-circuit breaking capacity of circuit breakers for relevant circuit of essential equipment is not to be less than the maximum prospective short-circuit current at the point of installation. For the A.C. systems, the rated operating short-circuit breaking capacity is not to be less than the prospective symmetrical short-circuit current (mot-mean-square value) at the point of installation.

2.5.3.3 The rated short-time withstanding current of category B circuit breakers (with short time-lag) is not to be less than the maximum prospective short-circuit current at the contact breaking time at the point of installation. For the A. C. systems, the rated short-time withstanding current is not to be less than the prospective symmetrical short-circuit current (mot-mean-square) at the contact breaking time at the point of installation.

2.5.3.4 Unless otherwise stated in 2.5.3.5, the rated short-circuit making capacity of every circuit breaker or switch intended to be closed on a short-circuit is to be not less than the maximum peak value of the prospective short-circuit current at the point of installation.

2.5.3.5 The use of a circuit-breaker having a short-circuit breaking and/or making capacity less than the maximum prospective short-circuit current at the point where it is installed is permitted, provided that it is backed up by a fuse or by a circuit-breaker on the generator side having at least the necessary short-circuit rating and not being the generator circuit-breaker.

The short-circuit performance of the arrangement is to be at least equal to the requirements of the standards@ accepted by the Society for a single circuit-breaker having same short-circuit performance category as the backed-up circuit-breaker and rated for the maximum prospective short-circuit level at the supply terminals of the arrangement.

2.5.3.6 The back-up protection complying with the requirements of 2.5.3.5 may be used non-essential services and essential service with automatic changing functions. The same fuse or circuit-breaker may be used to back up more than one circuit-breaker when essential services are not involved.

2.5.3.7 Circuit-breakers with fuses connected to the load side may be used, provided the back-up fuses and the circuit-breakers are of co-ordinated design, in order to ensure that the operation of the fuses takes place in due time so as to prevent arcing between poles or against metal parts of the circuit breakers when they are submitted to overcurrent involving the operation of the fuse.

2.5.3.8 When determining the performance requirements for the above-mentioned back-up protection arrangement, it is permitted to take into account the impedance of the various circuit elements of the arrangement, such as the impedance of a cable connection when the backed-up circuit-breaker is located away from the back-up circuit-breaker or fuse.

2.5.4 Selective protection for short-circuit

2.5.4.1 Unless otherwise stated in 2.5.3.6 , the short-circuit protection of essential equipment is to be selective and comply with the following:

- a. To ensure that only the switching device nearest t the fault initiates disconnection of the defective circuit in the case of short-circuit;
- b. The tripping time of t protective devices connected in series is to be carefully coordinated;
- c. During the required time of selective protection, the switching device is to be capable of carrying the short-circuit current not breaking at the point of installation.

2.5.5 Choice of protective devices against overload

2.5.5.1 Circuit breakers provided for overload protection am to have a tripping characteristic (overcurrent-trip time) adequate for the overload ability of the elements of the system to be protected and for any discrimination requirements.

2.5.5.2 The use of fuses for overload protection is permissible up to 320 A, provided they have suitable characteristics, but the use of circuit breakers or similar devices for overload protection is recommended above 200 A.

2.5.6 Protection of generators

2.5.6. 1 Generators are to be protected against short-circuit and overloads by circuit breakers arranged to open simultaneously all insulated poles, and in particular, the overload protection is to be adequate for the thermal capacity of the generator and within the following requirements:

- a. For overloads of less than 10% , an audible alarm signal may be included, which is operated by a time delay relay set at a maximum of 1.1 times the rated current of the generator and with a time delay of not more than 15 min.
- b. For overloads between 10% and 50%, the circuit breaker is to be tripped with a time delay of less than 2 min. It is recommended that the circuit breaker be set within the limits of 125 to 135 % of the rated current of the generator and with a time delay of 15 to 30s.
- c. For overcurrent in excess of 50% but less than the steady short-circuit current of the generator, instantaneous tripping after a short-time delay is to be co-ordinated with the discriminative protection of the system. It is recommended that the pick-up current of the circuit-breaker be set at 200% to 250% of the rated current of the generator and with a maximum time delay of 0.2s (D.C.) or 0.6s (A.C.).
- d. Circuit breakers for three or more than three generators connected in parallel are also to be provided with short- circuit instantaneous release which are to be set slightly greater than the maximum short-circuit current of the generators protected so that the circuit-breaker may break instantaneously.

2.5.6.2 For generators less than 50kW (kVA) in unit capacity and not arranged to operate in parallel, a multi-pole linked switch with a fuse in each insulated pole may be fitted for protection.

2.5.6.3 Generators having a capacity of 1500 kVA or above, are to be equipped with a suitable protective device or system which in the case of short-circuit in the generator or in the supply cable between the generator and its circuit breaker will de-excite the generator and open the circuit breaker.

2.5.6.4 A. C. generators arranged to operate in parallel are to be provided with a reverse-power protection, with a time delay set within 3 to 10s. D.C. generators arranged for parallel operation are to be provided with instantaneous or short-time delayed (less than one second) reverse current protection. The setting of reverse power (or reverse current) protection of generators arranged for parallel operation, dependent on the types of prime mover used, is to be as follows :

- a. For diesel engines - 8% to 15% of the rated power (or current) of the generator;
- b. For steam turbines - 2% to 6% of the rated power (or current) of the generator.

A fall of 50% in the applied voltage is not to render the reverse power (or reverse current) protection inoperative, although it may alter the amount of reverse power required to open the breaker.

The reverse-current protection is to be adequate to deal with the reverse-current conditions emanating from the ships network (e.g. cargo winches).

When an equalizer connection is provided, the reverse current device is to be connected on the positive pole of D.C. generators.

2.5.6.5 Generators arranged to operate in parallel are to be provided with undervoltage protection which is to be as follows:

- a. The operation of undervoltage release is to be instantaneous when used to prevent the closure of the circuit-breaker while the generator is not generating.
- b. When the voltage drops down to 70% -35 % of the rated voltage, the undervoltage release is to operate with a time delay for discrimination purpose.

2.5.6.6 Where turbine-driven D.C. generating sets are arranged to operate in parallel, means are to be provided for the purpose of opening simultaneously all circuit-breakers of the generators when the overspeed tripping device of the driving turbine functions.

2.5.6.7 The protective arrangements associated with generators are to comply with the following requirements:

- a. They will remain to be effective even in the case of substantial reduction of speed of generators.
- b. They will permit the power to be restored immediately after the overload protective device operates.

2.5.7 Automatic load shedding

2.5.7.1 Proper load shedding arrangements are to be provided in order to disconnect automatically the excess non-essential load when any one generator is overloaded. This load shedding may be carried out in one or more stages according to the overload ability of the generating sets.

2.5.8 Protection of power and lighting transformers

2.5.8.1 The primary windings of power and lighting transformers are to be protected against short-circuit and overload by multi-pole circuit-breakers or fuses. Overload protection may also be provided in the secondary windings.

2.5.8.2 When transformers are arranged to operate in parallel, means of isolation are to be provided on the secondary windings. Switches and circuit breakers used for this purpose are to be capable of withstanding surge currents.

2.5.9 Protection of feeder circuits

2.5.9.1 Each distribution circuit is to be protected against overload and short circuits by means of multi-pole circuit breakers arranged to open simultaneously all insulating poles, or multi-pole switch and fuses.

2.5.9.2 When a multi-pole switch and fuses are used, attention is drawn to the following requirements:

- a. The fuses in the distribution circuits from the main switchboard are to be installed between the busbar and the switch.
- b. For final sub-circuit from the distribution board, having a rated current not exceeding 60 A, and the consumers supplied by such sub-circuit can be cut-out at a nearby position, the switch may be omitted.

2.5.9.3 Circuits supplying consuming devices having individual overload protection (e . g . motors) may be provided with short-circuit protection only.

2.5.9.4 The protection of the steering gear circuits is to comply with these regulations.

2.5.9.5 Permanently fixed cables between the shore connection box and the main switchboard are to be protected by a circuit-breaker or an isolating switch and fuses. Such protection devices are to be fitted in the shore connection box.

2.5.9.6 In general, the interconnector feeder supplying the emergency switchboard from the main switchboard is to be protected at the main switchboard against overload and short-circuit. Where the system is arranged for feed-back operation, the interconnector feeder is also to be protected at the emergency switchboard at least against short-circuit.

2.5.10 Protection of motors

2.5.10.1 Motors of rating exceeding 0.5 kW and all motors for essential services are to be protected individually against overload and short-circuit, and also protected against undervoltage as required in 2.5.10.6.

The short-circuit protection can be provided by the same protective device for the motor and its supply cable.

2.5.10.2 Protection of steering gear motors is to comply with these regulations.

2.5.10.3 The protective devices are to be designed to allow current to pass during the normal accelerating period of motors according to the conditions corresponding to normal use. When the time-current characteristics of the overload protective device of a motor are not adequate for the starting period of the motor, the overload protecting device may be rendered inoperative during the accelerating period provided that the protection against short-circuit remains operative and that the suppression of the overload protection is only temporary.

2.5.10.4 For continuous duty motors, protective devices are to have a time delay characteristic which ensures reliable thermal protection of the motors for overload conditions. The maximum continuous current of the protective device is not to exceed 125 % of the rated current.

2.5.10.5 For intermittent duty motors, the current setting and the delay characteristics for protective devices are to be chosen after considering the actual service conditions.

2.5.10.6 Motors are to be provided with either:

- a. Undervoltage protection, operative on the reduction or failure of voltage, to cause and maintain the interruption of power in the circuit until the motor is deliberately restarted; or
- b. Undervoltage release, operative on the reduction or failure of voltage, but so arranged that the motor restarts automatically and without excessive starting current on restoration of voltage. The protective devices are to allow the motor to start when the voltage is above 85% of the rated voltage, and are without fail to intervene when the voltage is lower than approximately 20% of the rated voltage, at rated frequency, and with time delay when necessary.

2.5.10.7 When fuses are used to protect polyphase motor circuits, consideration is to be given to protection against single phasing.

2.5.11 Protection of lighting circuits

2.5.11.1 Each lighting circuit is to be protected against overload and short-circuit.



2.5.12 Protection of storage batteries

2.5.12.1 Storage batteries, other than engine starting batteries, are to be protected against short-circuit with devices placed as near as practicable to the batteries.

2.5.12.2 Charging facilities are to be protected against reversal of current due to the reduction or loss of charging voltage.

2.5.13 Protection of meters, pilot lamps and control circuits

2.5.13.1 Voltmeters, voltage coils of measuring instruments, each indicating devices and pilot lamps, together with their connecting leads are to be protected by fuses. A pilot lamp need not be individually protected provided the following conditions are satisfied:

- a. The pilot lamp is installed in the same enclosure and as an integral part of another item of equipment;
- b. The pilot lamp is supplied from the interior circuit of the enclosure of the equipment;
- c. The protection device in the circuit is rated less than 25 A;
- d. A fault in a pilot lamp would not jeopardize the supply to essential equipment.

2.5.13.2 The voltage coils of control and protective devices and equipment are to be protected by fuses. The coils need not be individually protected provided the following conditions are satisfied:

- a. Coils are installed in the same enclosure and as an integral part of another item of equipment, and are protected by a main protective device;
- b. The coils are supplied from circuits of the equipment and the protective device of such circuits is rated less than 25 A.

2.5.14 Power electronic devices

2.5.14.1 Power electronic devices are to be protected against overload and short circuit.

2.6 AUXILIARY MECHANISMS

2.6.1 General requirements

2.6.1.1 Motors rated at 1 kW or above and motors required for essential services are to be supplied from distribution boards by separate final sub-circuits.

2.6.1.2 Every electrical motor is to be provided with efficient means of starting and stopping which are, in general, placed near the motor, so as to be easily operated by the person controlling the motor.

2.6.1.3 Means are to be provided for the disconnection of the full load from all live poles of supply of every motor rated at 0.5 kW or above and its control gear. Where the control gear is mounted on or adjacent to a main or other distribution switchboard, a disconnecting switch in the switchboard may be used for this purpose. Otherwise, a disconnecting switch within the control gear enclosure or a separate enclosed disconnecting switch is to be provided.

2.6.1.4 When the starter or any other apparatus for disconnecting the motor is remote from the motor, it is required that either:

- a. Provision be made for locking the circuit disconnecting in the OFF position; or
- b. An additional disconnecting-switch be fitted near the motor; or
- c. The fuses in each live pole or phase be so arranged that they can be readily removed and retained by persons authorized to have access to the motor.

2.6.1.5 Where a single master-starter system (i.e. a starter used for controlling a number of motors successively) is used, the apparatus is to provide under voltage and over-current protection, and means of isolation and a running indicator for each motor not less effective than that required for systems using a separate starter for each motor. When the starter is of the automatic type, suitable alternative means are to be provided for manual operation. Where the starter is used for motors for essential services, the starting portion is to be duplicated, and means is to be provided for the transfer of the starting duties in the event of failure of one of the starters.

2.6.1.6 All motors with field adjustment speed control are to be provided with a device which renders the motors to be started only when the field is fully excited.

2.6.1.7 The undervoltage, overload and short-circuit protection for motors are to comply with the requirements of 2.5.

2.6.2 Steering gear

2.6.2.1 Electrical or electrohydraulic steering gear is to comply with the relevant requirements of these regulations.

2.6.3 Permanently installed submersible bilge pumps

2.6.3.1 The motors of permanently installed submersible bilge pumps are to be connected to the ships service emergency switchboard. The cables are to be installed in continuous lengths from above the bulkhead to the motor terminals.

The cables are to be impervious-sheathed and armoured. Cables and their connections to such pumps are to be capable of operating under a head of water equal to their distance below the bulkhead deck.

2.6.3.2 Under all circumstances it is to be possible to start the motor of a permanently installed submersible bilge pump from a position above the bulkhead deck. If an additional start-stop push button is provided near the motor, the circuits are to be so arranged as to ensure that all control circuits of the start-stop push button may be disconnected from the position above the bulkhead deck.

2.6.3.3 The source of power of a permanently installed submersible bilge pump is also to comply with the relevant requirements of these regulations.

2.6.4 Deck machinery

2.6.4.1 Electromagnetic brakes for electrical deck machinery are to have, in addition, a hand release device.

2.6.4.2 If not otherwise specially required in the specifications, the duty of windlass motors and warping winch motors is not to be less than 30 min rating.

2.6.4.3 Boat winch motors are to be provided with limit switches for cutting off the power supply upon the returning of boat to its original position.

2.6.4.4 The control device of boat winch motors is to be interlocked with the manual drive and manual brake.

2.6.5 Fire extinguishing systems

2.6.5.1 The electrical power supply to fire pump motors, fixed emergency fire pump motors, automatic sprinkler systems and fixed pressure water-spraying systems is to comply with the relevant requirements of these regulations.

2.6.6 Emergency stops for ventilating fans and oil pumps

2.6.6.1 All power ventilation systems of passenger ships carrying more than 36 passengers, except machinery space and cargo space ventilation and the requirements of these regulations, are to be fitted with master controls so that all fans may be stopped from either of two separate positions situated as far apart as practicable. Controls provided for the power ventilation serving machinery spaces are also to be grouped so as to be operable from two positions, one of which is to be outside such spaces, and such controls are to be located in positions having a safe access from the weather deck. Fans serving power ventilation systems to cargo spaces are to be capable of being stopped from a safe position outside such spaces.

The exhaust fans in the exhaust ducts from galley ranges are to be capable of being shut off within the galley.

2.6.6.2 The requirements for stopping the power ventilation systems in passenger ships carrying not more than 36 passengers are as follows:

- a. The power ventilation of accommodation spaces, service spaces, cargo spaces, control stations and machinery spaces is to be capable of being stopped from an easily accessible position outside the space being served. This position is not to be readily cut off in the event of a fire in the spaces served. The means provided for stopping the power ventilation of the machinery spaces are to be entirely separate from the means provided for stopping ventilation of other spaces.
- b. The means provided for stopping the power ventilation of the above-said machinery spaces are to be located in positions having a safe access from the weather deck.
- c. The exhaust fans in the exhaust ducts from galley ranges are to be capable of being shut off within the galley.

2.6.6.3 The requirements for stopping the power ventilation systems in cargo ships are to be the same as stated in 2.6.6.2 (a) and (c).

2.6.6.4 Forced and induced draught fans, oil fuel transfer pumps, boiler fuel-unit pumps and other similar fuel pumps are to be provided with an emergency stopping device located outside the space concerned so that they may be stopped in the event of a fire arising in the space in which these pumps and fans are located. This position of the emergency stopping devices is not to be readily cut off in the event of a fire in the space served. In passenger ships, such emergency stopping devices are to be located in one position or grouped in as few positions as possible which have a safe access from the weather deck.

2.7 LIGHTING AND NAVIGATION LIGHTS

2.7.1 General requirements

2.7.1.1 Where a bulkhead lighting is adopted, the lighting ports are to be of robust construction and gastight type, and are to be provided with protective grids against mechanical damage, and the surface temperature is not to exceed the allowable temperature in the fitting location.

2.7.1.2 The lighting fittings fitted in cargo-holds, exterior passageways, or other spaces where they are liable to mechanical damage, are to be provided with robust protective grids. The lighting fittings located in such spaces where they are liable to considerable vibration are to be provided with means for damping the vibration. Where lighting fittings are directly fixed on wooden panelling or other inflammable materials, precautions are to be taken against overheating and fire.

2.7.1.3 The lighting switches for coal bunkers and holds in coal carriers, fire control stations, baggage rooms, mail rooms, provisions rooms, refrigerated spaces and other similar spaces are not to be fitted inside such spaces.

Switches for the lighting used in wet spaces and in other spaces where risk of explosion might arise are to be capable of isolating all insulating poles. The lighting fittings used in baggage rooms, mail rooms, provisions rooms and refrigerated spaces are to be provided with a pilot lamp at the switch.

2.7.1.4 The notice boards bearing the inscription “DANGER! HIGH VOLTAGE!” are to be provided in the spaces adjacent to the gas discharge lamps and where otherwise necessary.

2.7.2 Supply and control for lighting circuits

2.7.2.1 The lighting point supplied by each final sub-circuit of rating of more than 16 A at the lighting distribution boards is not to exceed one. The number of lighting points supplied by each final sub-circuit of rating 16 A or less at the lighting distribution boards is not to exceed:

for 55 V circuits or less: 10 points;

for 56 ~ 120 V circuits: 14 points;

for 121~ 250 V circuits: 24 points.

Except that in final sub-circuits for cornice lighting, panel lighting and electrical signs where lampholders are closely grouped, the number of points supplied is unrestricted provided that maximum operating current in the sub-circuit does not exceed 10 A.

Final sub-circuits for lighting are not to supply appliances for heating and power except that small galley equipment (e.g. toasters, mixers, coffee makers), small miscellaneous motors (e.g. desk and cabin fans, refrigerators), wardrobe heaters and similar items.

2.7.2.2 The lighting for main machinery spaces, large machinery spaces other than the main machinery space, large galleys, passageways (including exits), stairways to boat decks, public spaces as well as berthing compartments accommodating more than 16 passengers is to be supplied by two final sub-circuits and one may be the final sub-circuit for emergency lighting, so that even when any one of the circuits fails the remaining circuit could still maintain the necessary lighting for such spaces. The lighting points in different circuits for engine and boiler rooms are to be distributed alternately.

In machinery spaces, parts of the oil fuel system containing heated oil under pressure exceeding 0.18 MPa are to be adequately illuminated so that defects and leakage can readily be observed. In machinery spaces of category A and whenever practicable in other machinery spaces, the arrangements for storage, distribution and utilization of oil used in pressure lubrication systems are also to be adequately illuminated.

2.7.2.3 Each fire zone is to be provided with at least two separate lighting feeders.

2.7.2.4 The permanently fixed lighting in cargo holds is to be controlled exclusively by a lighting control box from which separate circuits are to be provided for each cargo hold. Each outgoing circuit from the control box is to be fitted with a fuse and switch on the insulated pole, and in addition, to be provided with a pilot lamp to show whether the supply is on. The switch handles are not to be protruded out of the box. The door of boxes is to be provided with a lock. The control box is to be located in a suitable position outside the cargo holds.

Lighting of coal bunkers and cargo spaces of coal carriers is to be controlled by multi-pole linked switches situated outside these spaces. Provision is to be made for the complete isolation of these circuits and locking in the off position of the means of control.

2.7.2.5 The degree of protection of lighting fittings located in various spaces in ships is to comply with the requirements of Table 1.3.2.2.

Lighting switches for spaces with special circumstances are to be installed in accordance with the requirements of 2.7.1.3.

Where bulkhead lighting arrangements are adopted in spaces where risk of explosion might arise, they are to comply with the requirements of 2.7.1.1.

2.7.2.6 Lighting circuits are to be provided with protection in accordance with the requirements of 2.5.11.1.

2.7.2.7 A main electrical lighting system which provides illumination throughout those parts of the ship normally accessible to and used by passengers or crew is to be supplied from the main source of electrical power.

2.7.3 Emergency lighting

2.7.3.1 The arrangement of emergency lighting and supplementary emergency lighting for m-m passenger ships is to comply with the relevant requirements of 2.2.

2.7.3.2 In the passenger ships, the means of escape, including stairways and exits, are to be marked by lighting or photoluminescent strip indicators complying with the standards accepted by the Society placed not more than 0.3 m above the deck at all points of the escape route including angles and intersections. The marking must enable passengers to identify all the routes of escape and readily identify the escape exits. If illumination is used, it is to be supplied by the emergency source of power (see 2.2.2.1(a) ①).

2.7.3.3 All emergency lighting fittings are to be provided with a prominent mark or structurally different from other luminaries.

2.7.3.4 No switch is to be installed in the transitional emergency lighting feeders.

2.7.3.5 No local switch is to be installed in the emergency lighting circuits except for the emergency lights in the navigating bridge, at the stowage space of lifeboats and liferafts and emergency lighting serving as the main lighting.

2.7.3.6 Each electrical power source, the associated transforming equipment (if any), the main or emergency switchboard and lighting switchboard (excluding section board and distribution board) for main and emergency lighting systems are not to be provided in the same place in order that the two systems would not fail in the event of a fire or other casualty in any places where the systems installed.

2.7.4 Navigation lights

2.7.4.1 Each navigation light is to be connected separately to the control box and is to be controlled and protected in each insulated pole by a switch and fuse or by a circuit breaker fitted in the control box.

2.7.4.2 Control box for navigation lights is to be supplied directly from the emergency switchboard and transitional emergency charging and discharging switchboard (where the transitional source of emergency power is required according to 2.2), or directly from the emergency switchboard and main switchboard.

2.7.4.3 The change-over switch for the supply circuits required in 2.7.4.2 is to be installed on the control box or at a suitable location in the navigation bridge.

2.7.4.4 Each navigation light is to be provided with an automatic indicator giving an audible and visual indication of failure of the light. If a visual signal is used and connected in series with the navigation light, means are to be provided to prevent extinction of the navigation light due to failure of the signal, and the audible and visual alarms for failure of the source of electrical power of the control box are to be provided.

2.7.4.5 The control box of navigation lights may be extended to supply power for the signal lights required in International Regulations for Preventing Collisions at Sea and other electrical equipment are not to be switched in the box.

2.8 INTERNAL, COMMUNICATION SYSTEMS

2.8.1 Main engine telegraph system

2.8.1.1 At least two independent means are to be provided for communicating orders from the navigating bridge to the position in the machinery space or in the control room from which the propeller revolution and thrust direction (hereinafter called normal control position of propeller) are normally controlled. One of the means is the main engine telegraph system complying with the requirements of 2.8.1.2.

2.8.1.2 The main engine telegraph system is to be in compliance with the following requirements:

- a. The controls of the transmitters and receivers are to be safeguarded by suitable means against inadvertently move;
- b. Engine telegraphs are to be two-way systems in which the signal given by the receiver is also immediately discernible at the transmitter;
- c. In the case of installations with several control positions the acknowledged command must be indicated at all control positions. Where control positions are selected by switching, additionally indication is to be provided of which one is in use;
- d. Transmitters and receivers are to be equipped with call-up devices which remain in operation from the start of the command transmission till it is correctly acknowledged. The audible signal is to be

hearable at all points in the engine room. If necessary, visual signals are to be provided in addition to the audible signals;

- e. Audible alarm is to be provided for fault direction of main engine in the normal control position of propeller;
- f. Power is to be supplied by the independent final sub-circuit and audible and visual alarms are to be installed on the bridge for the purpose of indicating the failure of power supply.

2.8.1.3 The other means for communicating orders required in 2.8.1.1 may be the emergency engine telegraph system, which functions are to be in compliance with the requirements of 2.8.1.2 (a) and (b) , and supplied by the emergency power source.

2.8.1.4 A telephone system required in 2.8.2.2 (d) may be fitted instead of the emergency engine telephone system.

2.8.2 Important telephone system

2.8.2.1 The important telephone system is to be designed to ensure fully satisfactory vocal intercommunication under all working conditions.

2.8.2.2 The telephone system is to be provided in the following spaces:

- a. Bridge - Engine control room;
- b. Bridge - Steering gear control position in steering gear compartment;
- c. Bridge - Radio room, not required if communication can be made without telephone;
- d. Bridge - normal control position of propeller, not required if emergency main engine telegraph system is provided;
- e. Bridge - Other control positions of propeller, not required if repeater of main engine telegraph is provided in these positions;
- f. Engine control room - Other control positions of propeller, not required if repeater of main engine telegraph is provided in these positions;

2.8.2.3 The telephone system required in 2.8.2.2 are to be individual links, although this feature may be dispensed with if it is ensured that the bridge can cut into existing conversations at all times. Important telephone system is to be independent.

2.8.2.4 Two-way calling equipment is to be provided for the telephone systems fitted in the engine room (except engine control room) and to be designed hearable at all points of the engine room under the full-power operation condition of main propelling plant, visual signals are to be provided in addition to the audible signals.

2.8.2.5 The important telephone system is to be operable in the case of a failure of the main power supply.

2.8.3 Communications in an emergency

2.8.3.1 An intercommunication system is to be provided which enables commands to be transmitted between strategically important positions, the emergency control station, the muster and embarkation station of life-saving boats and rafts and bridge room, etc.

2.8.3.2 The communication system may comprise portable or permanently installed equipment, and is to be operable in the case of a failure of the main power supply.

2.8.4 Alarms for engineers

2.8.4.1 Alarms for engineers are to be provided which can be controlled from engine room or engine control room and be hearable in the engineers' accommodation areas.

2.8.4.2 The audible alarm may be mounted centrally in the passageway of the engineers' accommodation, or individually in the cabins and the mess. Where a decentralized arrangement is used, it is to be possible to transmit the alarm to the engineers both singly and collectively.

2.9 SAFETY SYSTEM FOR SHIPS AND PERSONS ABOARD

2.9.1 General emergency alarms

2.9.1.1 In order to give general emergency signals, a general emergency alarm comprises of bell, small-type ringing whistle or other equivalent equipment is to be provided. In passenger ships, the alarm is to be capable of giving separately to crew and passengers simultaneously.

2.9.1.2 The alarm system is to be operable from the bridge and fire control station and sound continuously until it is switched off manually or is interrupted by the public address system.

2.9.1.3 Where the general emergency alarm system is under working condition, acoustic system for entertainment is to be interrupted automatically.

2.9.1.4 The general alarm system is powered by special feeders, if the main electrical power source fails, it is to be powered by the emergency electrical power source automatically. In passenger ships, the system is also be powered by temporary emergency electrical power source.

2.9.1.5 The system is to be audible throughout all the accommodation and normal crew working spaces, including weather decks in passenger ships.

The minimum sound pressure levels for the emergency alarm tone in interior and exterior spaces are to be 80 dB (A) and at least 10 dB (A) above ambient noise levels existing during normal equipment operation

with the ship underway in moderate weather. The sound pressure levels at the sleeping position in cabins and in cabin bathrooms are to be at least 75 dB (A) and at least 10 dB (A) above ambient noise levels. In cabins without a loudspeaker installation, an electronic alarm transducer is to be installed, e.g. a buzzer or similar.

2.9.1.6 Public address system or other suitable communications are to be supplemented for the general emergency alarm system.

2.9.2 Public address system

2.9.2.1 Cargo ships of 500 gross tonnage and above are to be provided with the public address system in compliance with the following requirements:

- a. Enables broadcast of messages from bridge and fire control station, etc. to all spaces where crew are normally present and the muster station;
- b. Unnecessary for the receivers to take any measures to accept the broadcast message;
- c. Protected against unauthorized use;
- d. The amplifiers are to behave the sufficient output power so that all loudspeakers for the purpose of emergency announcement can be operated at the same time;
- e. The system is to be arranged to prevent feedback and other interference;
- f. With the ship underway in normal conditions, the minimum sound pressure levels for broadcasting emergency announcements are to be:
 1. In interior space 75 dB (A) and at least 20 dB (A) above the speech interference level;
 2. In interior space 80 dB (A) and at least 15 dB (A) above the speech interference level;
- g. The system is powered by main electrical power source and emergency electrical power source.

2.9.2.2 All passenger ships are to be provided with the public address system in compliance with the following requirements:

- a. To enable simultaneous broadcast of messages from bridge and central control station, etc. to all spaces where crew and passengers, or both are normally present and to muster station, also enables broadcast of messages to the crew and passengers separately;
- b. To comply with the requirements of 2.9.2.1(b) to (f);
- c. The controls of the system on the control position in bridge is to be capable of interrupting any broadcast on the system from any other positions onboard;
- d. The spaces of system control units and the control stations required in the definitions of these regulations, the system is to have the emergency function control at each control station which:
 1. Is clearly indicated as the emergency function;
 2. Automatically overrides any other input system or programme;
 3. Automatically overrides all volume controls and on/off controls so that the required volume for the emergency mode is achieved in all spaces;
- e. At least two amplifiers are to be provided, each of them separately supplied and fused;

- f. At least two loudspeaker circuits supplied from separate amplifiers, are to be installed in each fire zone, and the cables are to be laid separately along the whole length as far as possible;
- g. Independent short-circuit protection is to be provided for each loudspeaker;
- h. The system is to be powered by main electrical power source, emergency electrical source and temporary emergency electrical power source.

2.9.3 Pre-discharge alarms of fire extinguishing systems

2.9.3.1 In any spaces where personnel normally work or access, automatic audible alarm is to be provided for discharge of fire extinguishing. The system is to be operated at least 20s before the medium is released.

2.9.3.2 The alarm system is powered by emergency electrical power source.

2.9.4 Elevator alarms

2.9.4.1 An emergency audible device capable of being operated in its car is to be provided for elevators having central control and the alarm is to be transmitted to the positions where personnel are normally present.

2.9.4.2 The emergency audible alarm is to be independent from the power and control circuits of the elevator and is powered by emergency electrical power source.

2.9.5 Closing alarm for refrigerated spaces

2.9.5.1 Where the doors to refrigerated spaces such as refrigerated holds and refrigerating food chamber cannot be opened from the interior, a closing alarm device capable of activating within the spaces and transmitting to the spaces where personnel are normally present

2.9.6 Fire detection and fire alarm systems

2.9.6.1 The fire detection and fire alarm systems are to comply with the relevant requirements of these regulations.

2.9.7 Fire-protection doors

2.9.7.1 The power, control, indication and alarm system of fire-protection doors required in PART SIX are supplied by the emergency electrical power source.

2.9.7.2 Indicator to show whether each door operated by remote control is opened or closed is to be provided in the control station where personnel are normally present.

2.9.7.3 The control and indication systems for the fire-protection doors are to be designed on the fail-safe principle with the release system having a manual reset, which is capable of being operated from either side of the doors.

2.9.8 Watertight doors in passenger ships

2.9.8.1 The power circuit and its associated control, indication and alarm circuits for power-operated sliding watertight doors are to be supplied by emergency switchboard either directly or by a dedicated distribution board connected with the emergency switchboard board above the bulkhead deck.

2.9.8.2 Where motor is provided for the opening and closing of the watertight doors, unless independent reserve energy is provided, the power source is to be capable of being automatically supplied by the transitional source of emergency electrical power in the event of failure of either the main or the emergency source of electrical power and with sufficient capacity to operate the watertight doors at least three times, i. e. closed - open - closed.

2.9.8.3 A single electrical failure in the power operating or control system of a power-operated sliding watertight door is not result in a closed door opening or interrupts any manual operation of the watertight door.

2.9.8.4 Availability of power supply is to be continuously monitored at a point in the electrical circuit as near as practicable to operating equipment for watertight doors. Loss of any such power supply is to activate an audible and visual alarm at the central operating console at the bridge.

2.9.8.5 Electrical power, control, indication and alarm circuits are to be protected against fault in such a way that a failure in one door circuit will not cause a failure in any other door circuit. Short circuits or other faults in the alarm or indicator circuits of a watertight door are not result in a loss of power operation of that door. Arrangements are to be such that leakage of water into the electrical equipment located below the bulkhead deck will not cause the door to open.

2.9.8.6 The enclosures of electrical components necessarily situated below the bulkhead deck are to have the protection grades against the ingress of water:

- a. Electrical motors, associated circuits and control components: IPX7 ;
- b. Door position indicators and associated circuit components : IPX8 ;

The water pressure testing is to be based on the pressure that may occur at the location of the component during flooding for a period of 36 h;

- c. Door movement warning signals: IPX6.

2.9.8.7 Electrical control equipment of watertight doors, including cables, are to be kept as close as practicable to the bulkhead in which the watertight doors are fitted, in order to minimize the likelihood of them being involved in any damage which the ship may sustain.

2.9.8.8 An audible alarm, distinct from any other alarm in the area, is to be provided, which will sound whenever the watertight is closed remotely by power and is to sound for at least 5 s but not more than 10 s before the door begins to move and is to continue sounding until the door is completely closed. In passenger areas and areas of ambient noise exceeding 85 dB (A), the audible alarm is to be supplemented by an intermittent visual signal.

2.9.8.9 The central operating console is to be in the bridge, having a master mode switch with the following two modes of control:

- a. Local control mode for normal conditions, which is to allow any watertight door to be locally opened and locally closed after use without automatic closure;
- b. Door closed mode for emergency conditions, which is to automatically close any watertight that is open and permit doors to be opened locally and to automatically reclose the doors upon release of the local control mechanism.

2.9.8.10 The central operating console at the bridge is to be provided with a diagram showing the location of each watertight door, with visual indicators to show whether each watertight door is open or closed. A red light is to indicate a door is fully open and a green light is to indicate a door is fully closed. When the door is closed remotely, the red light is to indicate the intermediate position by flashing. The indicating circuit is to be independent of the control circuit for each watertight door.

2.9.8.11 It is not to be possible to remotely open any watertight door from the central operating console.

2.9.9 Watertight access doors and hatch covers, etc. in cargo ships of 80 m or above in length

2.9.9.1 In order to ensure the operation, control and indication of sliding watertight doors on the internal openings which are used while at sea, the following requirements are to be in compliance with:

- a. To be capable of closing remotely at the bridge and operating at the either side of the bulkhead;
- b. Indicator to show whether the door is open or closed is to be provided in the control position;
- c. Audible and visual alarms are to be given as the door is closed;
- d. Each door is to be provided with an individual hand-operated mechanism, which is to be possible to open and close by hand at the door itself from both sides.

2.9.9.2 Access doors and hatch covers normally closed at sea, intended to ensure the watertight integrity of internal openings, are to be provided with means of indication locally and on the bridge showing whether these doors or hatch covers are open or closed.

2.9.9.3 External openings of compartments located below the assumed final waterline, except for cargo hatch covers, are to be fitted with indicators on the bridge to show whether the openings are open or closed.

2.9.9.4 The electrical power, control, indication and audible and visual alarms required in 2.9.9.1 to 2.9.9.3 are to be capable of continuous operation in the event of the failure of main electrical power source.

2.9.10 Bow doors, stern doors, shell doors, loading doors and other closing appliances in ro-ro passenger Ships

2.9.10.1 In order to ensure the watertight integrity of ship's structure, the bow doors, stem doors, shell doors, loading doors and other closing appliances are to be provided with an indicator in accordance with the requirements of these regulations. The indicator is to be designed on the fail-safe principle to show whether the doors or closing appliances are open or not fully closed or fully closed.

2.9.10.2 The screen of indicator required in 2.9.10.1 is to be provided in the bridge, and it is to be equipped with a mode selection function "harbour/sea voyage" so that an audible and visual alarm is given from the bridge if the ship leaves harbour with the bow doors, stem doors, shell doors, loading doors and other closing appliances not closed or any closing appliances not in the correct position.

2.9.10.3 The power supply for the indicator is to be independent of that for operating and securing the doors.

2.9.10.4 Television surveillance and a water leakage detection system with audible alarm are to be arranged to provide an indication to the bridge and to the engine control mom of any leakage through bow doors, stem doors, shell doors, loading doors or other closing appliances.

2.10 HEATING AND COOKING EQUIPMENT

2.10.1 General requirements

2.10.1.1 All space-heating appliances are to be installed permanently in positions.

2.10.1.2 Heating appliances are not to be installed in positions where the combustible gases and dusts are likely to accumulate.

2.10.1.3 Heating appliances are to be so mounted that there will be no risk of excessive heating of adjacent decks, bulkheads or other surroundings.

2.10.2 Control and installation of heating and cooking equipment

2.10.2.1 Each item of heating or cooking equipment is to be controlled as a complete unit by a multi-pole linked switch mounted in the vicinity of the equipment. In the case of cabin heaters, a single-pole switch will be acceptable.

2.10.3 Supply of heating equipment

2.10.3.1 Each heater is to be connected to a separate final sub-circuit for heating except that up to ten small heaters of total connected current rating not exceeding 16 A may be connected to a single final sub-circuit for heating.

2.11 STORAGE BATERIES

2.11.1 Arrangement and installation

2.11.1.1 Storage batteries are not to be installed in positions where they are exposed to excessively high or low temperatures, water spray or other factors liable to impair their serviceability or shorten their service life. They are to be installed in such a way that persons cannot be endangered and equipment cannot be damaged by exhausted gases or leaked-out electrolytes.

2.11.1.2 Storage batteries are to be so installed as to ensure accessibility for changing cells, inspection, testing, topping-up and cleaning.

2.11.1.3 Storage batteries are not to be installed in the accommodation area. An exception may be granted for gastight cells, where charging does not result in the development of harmful gases.

2.11.1.4 Suitable protection measures are to be provided where the storage batteries will be sustained by mechanical damage or dropping objects.

2.11.1.5 Storage batteries with a charging capacity of up to 2 kW may be installed in a room assigned to the batteries only, but may be installed in a deck box or a locker where the batteries are installed on the weather deck.

2.11.1.6 Storage batteries with a charging capacity of 0.2 kW to 2 kW may be installed in accordance with the requirements of 2.11.1.5. They also may be installed in a deck box or a locker in suitable locations, or may be installed open in a machinery space with a good ventilation.

2.11.1.7 Storage batteries with a charging capacity less than 0.2 kW may be installed in open locations of any suitable spaces or in a room assigned to the batteries only.

2.11.1.8 Supports made of non-absorbent, electrolyte-resistant insulating material are to be provided below each crate of cells to a height of not less than 20 mm, and an air gap of more than 20 mm wide is to be provided around each crate of cells by means of spacers made of the same material. Suitable measures are to be taken to prevent any electrolyte from lodging in contact with the ship's structure.



2.11.1.9 The interior surface of battery rooms, boxes, lockers or ventilation ducts, etc. liable to corrosion, by the electrolyte or by the gas emitted from the electrolyte, are to be protected against corrosion by suitable means.

2.11.1.10 Engine starter batteries are to be installed as close as practicable to the engine served.

2.11.1.11 Storage batteries for emergency electrical power source and temporary electrical power source are to be installed in accordance with the requirements of 2.2.1.2.

2.11.1.12 Warning notice of “NO SMOKING AND NAKED LIGHTS” are to be fitted to the door of battery rooms, covers of boxes or lockers.

2.11.2 Ventilation

2.11.2.1 All battery rooms, boxes and lockers are to be ventilated in such a way as to prevent the accumulation of ignitable gas mixtures.

2.11.2.2 Natural ventilation can be used where the air ducts can directly extend from the top of battery rooms, boxes or lockers to the open air due to the fact of less necessary air change and the inclination of any part of ducts does not exceed 45° from vertical.

2.11.2.3 Mechanical ventilators are to be provided in the special battery rooms, boxes or lockers where gas-permeability storage batteries are installed, where the total charging power does not exceed:

- 3 kW for lead-acid storage batteries, or;
- 2 kW for nickel-cadmium storage batteries.

2.11.2.4 Except those boxes and lockers installed in the weather deck or the spaces required in 2.11.1.6 and 2.11.1.7, battery rooms, boxes or lockers are to be ventilated by an independent ventilating system. The outlet ducts are to extend to a space where can safely dilute the flammability gases without any ignitable source and the inlet ducts are to be in a space where flammability gases may be accumulated. The outlet is to be situated at the top while the inlet is at the bottom with the means to prevent the ingress of water and flame.

2.11.2.5 Measures are to be established for mechanical ventilators for battery rooms, boxes or lockers in order to prevent sparking arising from accidental contact of the impeller with the casing. The non-metal blades are made of antistatic materials.

2.11.2.6 All openings to battery rooms, other than ventilation openings, are to be effectively sealed to prevent the explosive gas from entering the adjacent compartments.



2.11.2.7 The quantity of air removed Q of the gas-permeability battery rooms, boxes and lockers is not to be less than:

$$Q = 0.11 I_n \quad \text{m}^3/\text{h}$$

Where:

I- the maximum charging current during the production of gas, but not less than 25% of the maximum charging current output by the charger, in A;

n - number of battery cells.

2.11.2.8 The quantity of air removed of the valve-regulated sealed battery rooms, boxes and lockers may be reduced to 25% of that required in 2.11.2.7.

2.11.3 Charging facilities

2.11.3.1 Charging facilities are to be provided for all storage batteries such that they may be completely charged from the completely discharged state in a reasonable time having regard to the service requirements.

2.11.3.2 Suitable means are to be provided for controlling and monitoring charging of storage batteries, and to protect them in accordance with the requirements of 2.5.12.2 of this PART.

2.11.3.3 For floating circuits or any other conditions where the load is controlled to the storage battery whilst it is on charge, the maximum battery voltage is not to exceed the safe value for any connected apparatus.

2.11.3.4 Where valve-regulated sealed batteries are installed, a device independent of the normal charging arrangements is to be provided to prevent gas evolution in excess of the manufacturer's design quantity.

2.11.3.5 Where fast charger is provided, mechanical ventilators are to be installed in battery rooms and are to be such that they are automatically disconnected when the ventilators fail.

2.11.4 Electrical equipment

2.11.4.1 Electrical equipment is to be avoided to install in the battery rooms. Where necessary, unless otherwise stated in 2.11.4.2, explosive electrical equipment required in 1.3.3.3 are to be selected, and the bulkhead lighting is to be used in accordance with the requirements of 2.7.1.1.

2.11.4.2 General electrical equipment may be installed in compartments containing valve-regulated sealed storage batteries provided that the ventilation requirements of 2.11.2.8 and the charging requirements of 2.11.3.4 and 2.11.3.5 are complied with.

2.12 CABLES

2.12.1 General requirements

2.12.1.1 Cables are to be selected according to the environmental conditions of the location, methods of installation, rated current, duty, diversity factor, permissible voltage drop, etc.

2.12.1.2 The rated voltage of any cable is not to be lower than the nominal voltage of the circuit for which it is used. Special consideration is to be required for cables exposed to voltage surges associated with highly inductive circuits, e. g. contactor operating circuits for cargo winches, etc.

2.12.1.3 Portable electrical equipment is to be provided with movable flexible cables.

2.12.1.4 Cables used in the non-earthing system are to be provided with suitable rate so as to sustain the additional stress of the cable insulation in the event of failure.

2.12.2 Choice of insulating material

2.12.2.1 The rated maximum operating temperature of the insulating material is to be at least 10°C higher than the maximum ambient temperature liable to be produced in the space where the cable is installed.

2.12.2.2 Insulating material of cables is generally to be selected in accordance with Table 2.12.2.2. The selection of other insulating materials is to be subject to agreement of the Society.

Table 2.12.2.2
Maximum working temperature of insulating material

Insulating material		Maximum operating conductor temp. (°C)		
		Normal working	Short-circuit	
Elastomeric thermoset compounds	or	Ethylene propylene rubber	85	250
		Cross-linked polyethylene	85	250
		Silicone rubber	95	submitted to the Society
		Halogen-free ethylene propylene rubber	85	250
		Halogen-free cross-linked polyethylene	85	250
		Halogen-free silicone rubber	95	submitted to the Society
Thermoplastic compounds		Polyvinyl chloride	60	150
		Heat-proof polyvinyl chloride	75	150
Other materials		Mineral	95	submitted to the Society

Note:

1. Silicone rubber and mineral insulation may be used for higher temperatures (to 150 °C for silicone rubber, unlimited for mineral insulation) when installed where they are not liable to be touched by ships personnel, but subject to agreement of the Society.
2. The temperature of the conductor is the combination of ambient temperature and temperature rise due to load.

2.12.3 Choice of protective covering

2.12.3.1 Cables permanently fitted on decks exposed to the weather, in bathrooms, cargo holds, refrigerated spaces, machinery spaces or in any other location where water condensation or harmful vapour (e.g. oil vapour) may be present are to have a metallic impervious sheath (copper or lead alloy) or a nonmetallic impervious sheath (polyvinyl chloride, polychloroprene, chlorosulphonated-polyethylene, etc.). The character of the impervious sheath is to satisfy the requirements for environmental conditions.

2.12.3.2 In permanently wet situations, metallic sheaths are to be used for cables with hygroscopic insulation.

2.12.3.3 All cables and wiring external to electrical equipment are to be at least of a flame-retardant type. In general, cables have been passed the bundled flame-retardant test in accordance with the standard accepted by the Society are to be used. Where the bundled cables are individually flame-retardant and have been passed the single flame-retardant test in accordance with the standards accepted by the Society, measures to limit the propagation of fire along cable and wire bundles (see 2.12.10).

2.12.3.4 Cables required to be operable under fire conditions, including those for their power supplies are to be of a fire resistant type, complying with the standards accepted by the Society, where they pass through high fire risk areas, fire zones or decks, other than those which they serve. The following may be exempted provided their functionality can be maintained under fire conditions:

- a. Systems that are self-monitoring;
- b. Systems designed in accordance with fail-safe principle;
- c. Duplicated with cable runs as widely separated as practicable.

2.12.3.5 Cables required to be operable under fire conditions include:

- a. General emergency alarm system;
- b. Fire detection and fire alarm system;
- c. Fire extinguishing system and fire extinguishing medium alarm;
- d. Public address system;
- e. Control and power systems to power operated fire doors and status indication for all fire doors;
- f. Control and power systems to power operated watertight doors and their status indication;
- g. Emergency lighting;
- h. Low location lighting.

2.12.3.6 Where necessary for particular applications the Society may permit the use of special types of cables which do not comply with the requirements of 2.13.3.3, such as radio frequency cables or digital computer information transmission system cables.

2.12.3.7 In choosing different types of protective coverings, due consideration is to be given to the mechanical actions to which each cable may be subjected during installation and in service.

If the mechanical strength of the protective covering is considered insufficient, the cable is to be fitted in pipes or conduits or trunking or be otherwise protected.

2.12.3.8 In areas attended by passengers and in service areas only halogen-free cables are to be used.

2.12.4 Determination of the cross-sectional area of conductor

2.12.4.1 The highest continuous load carried by a cable is not to exceed its current rating after the application of correction factors. The diversity factor of the individual loads and the duration of the maximum demand may be allowed in estimating the maximum continuous load.

2.12.4.2 The voltage drop from the main switchboard or emergency switchboard bus-bars to any point in the installation when the cable are carrying maximum current under normal conditions of service, is not to exceed 6% of the nominal voltage. Where the supply is from batteries with a voltage not exceeding 50 V, this voltage drop may be increased to 10%. For navigation lights it is necessary to limit voltage drops to lower values in order to maintain required lighting output and colour.

2.12.4.3 In assessing the current rating of lighting circuits, every lampholder is to be assessed at the maximum load likely to be connected to it, with a minimum of 60 W, unless the fitting is so connected as to take only a lamp rated at less than 60 W. Two lampholders are to be counted for each lighting socket.

2.12.4.4 Cables supplying cargo winches, cranes, windlasses and capstans are to be suitably rated for their duty.

2.12.4.5 The cross-sectional area of the conductors of equalizer cables for D. C. generators is not to be less than 50% of that of the main circuit cables, and the cross-sectional area of the conductors of neutral wires of three-phase four-wire system is to be the same as that of the phase wires.

2.12.5 Continuous service Current rating

2.12.5.1 The maximum continuous load carried by a cable is not to exceed the values as given in Table 2.12.5.1. The current ratings given in such tables are based on maximum operating conductor temperatures given in Table 2.12.2.2. Where a more precise evaluation of current rating has been carried out based on experimental or calculated data, details may be submitted to the Society for approval.

2.12.5.2 The continuous service of cables required in this Section is the service that the continuous service period of current with constant loading are three times longer than the time constant of cable, i.e. more than the critical duration (see Fig. 2.15.5.2).

Table 2.12.5.1

Current ratings for cables during continuous working time (based on ambient temp. 45 °C) (A)

Insulation	General polyvinyl chloride			Heat-proof polyvinyl chloride			Ethylene propylene rubber and cross-linked polyethylene			Silicon rubber and mineral insulation		
	single core	2 core	3 or 4 core	Single core	2 core	3 or 4 core	Single core	2 core	3 or 4 core	single core	2 core	3 or 4 core
Maximum conductor temp.	60 °C			75 °C			85 °C			95 °C		
mm ²	single core	2 core	3 or 4 core	Single core	2 core	3 or 4 core	Single core	2 core	3 or 4 core	single core	2 core	3 or 4 core
1	8	7	6	13	11	9	16	14	11	20	17	14
1.5	12	10	8	17	14	12	20	17	14	24	20	17
2.5	17	14	12	24	20	17	28	24	20	32	27	22
4	22	19	15	32	27	22	38	32	27	42	36	29
6	29	25	20	41	35	29	48	41	34	55	47	39
10	40	34	28	57	48	40	67	57	47	75	64	53
16	54	46	38	76	65	53	90	77	63	100	85	70
25	71	60	50	100	85	70	120	102	84	135	115	95
35	87	74	61	125	106	88	145	123	102	165	140	116
50	105	89	74	150	128	105	180	153	126	200	175	140
70	135	115	95	190	162	133	225	191	158	255	217	179
95	165	140	116	230	196	161	275	234	193	310	264	217
120	190	162	133	270	230	189	320	272	224	360	306	252
150	220	187	154	310	264	217	365	310	256	410	349	287
185	250	213	175	350	298	245	415	353	291	470	400	329
240	290	247	203	415	353	291	490	417	343	570	485	400
300	335	285	235	475	404	333	560	476	392	660	560	460

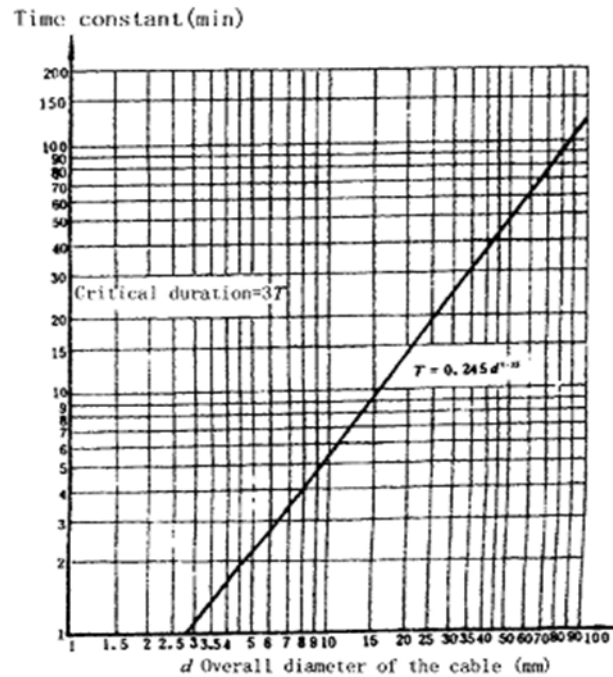

Fig. 2.12.5.2

2.12.6 Correction factors for current rating

2.12.6.1 Correction factors for different ambient temperatures. When it is known that the ambient temperature is different from 45 °C, correction factors given in Table 2.12.6.1 are to be applied.

Table 2.12.6.1

Correction factor ambient temperature

ambient temp. (°C)	35	40	45	50	55	60	65	70	75	80	85
Maximum operating conductor temp. (°C)											
60	1.29	1.15	1.00	0.82	—	—	—	—	—	—	—
65	1.22	1.12	1.00	0.87	0.71	—	—	—	—	—	—
70	1.18	1.10	1.00	0.89	0.77	0.63	—	—	—	—	—
75	1.15	1.08	1.00	0.91	0.82	0.71	0.58	—	—	—	—
80	1.13	1.07	1.00	0.93	0.85	0.76	0.65	0.53	—	—	—
85	1.12	1.06	1.00	0.94	0.87	0.79	0.71	0.61	0.50	—	—
90	1.10	1.05	1.00	0.94	0.88	0.82	0.74	0.67	0.58	0.47	—
95	1.10	1.05	1.00	0.95	0.89	0.84	0.77	0.71	0.63	0.55	0.45

2.12.6.2 Correction factors for branched cables

- a. Cables laid in one of the following manners and so arranged as to ensure free air circulation around each bunch may adopt the current ratings directly from Tables 2.12.5.1:
1. Not more than six cables bunched together on cable trays, in cable conduits, pipes or trunking;
 2. More than six cables arranged in the following manners:

Distances between any two sextuplets is equal to at least one diameter of the thickest cable



Or distances between any two triplets horizontally and vertically equal to at least one diameter of the thickest cable

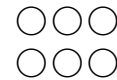
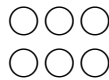
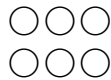

- b. Where more than six cables, which may be expected to operate simultaneously at their full rated capacity, are laid close together in a cable bunch⁰ in such a way that there is an absence of free air circulation around them, a correction factor of 0.85 is to be applied. When a corrector factor of 0.85 is used, care is to be taken that there are in general not more than two layers in each cable bunch.

2.12.6.3 Correction factors for non-continuous service

- c. For half-hour and one-hour services, the corresponding correction factors given by Fig. 2.12.6.3 (1) may be applied. These correction factors are applicable only if the intermediate periods of rest are longer than the critical duration given in Fig. 2.12.5.2.
- d. For intermittent service, the corresponding correction factors given in Fig. 2.12.6.3 (2) may be applied.

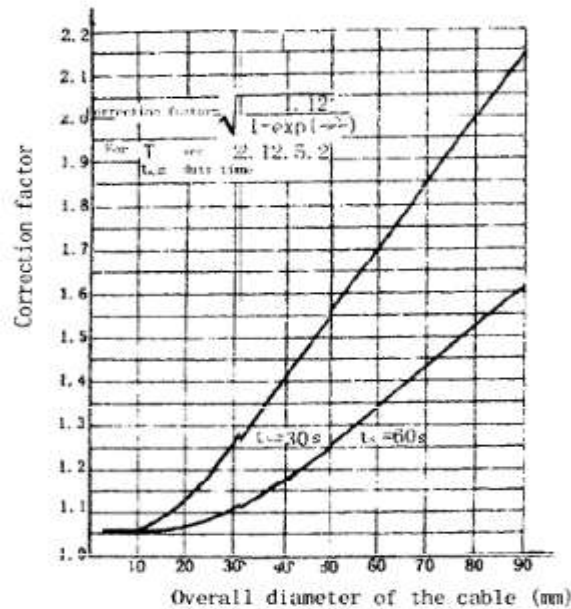

Fig 2.12.6.3(1) Correction factors for half-hour and one-hour services

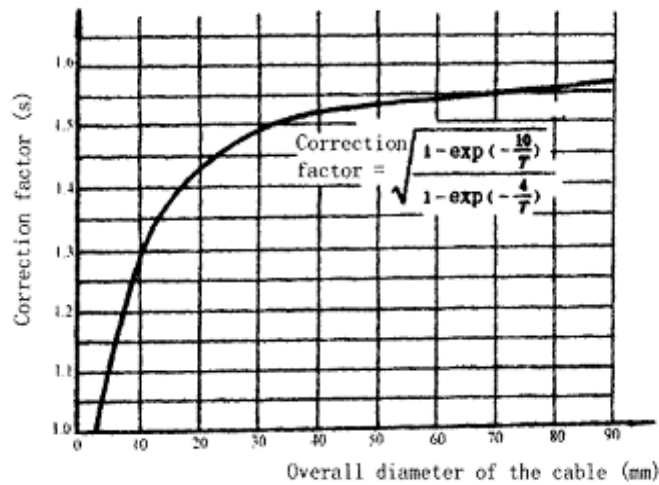

Fig 2.12.6.3(2) Correction factor for intermittent service

Note: The correction factor given in Fig. 2.12.6.3(2) has been roughly calculated for periods of 10 min, of which 4 min are with a constant load and 6 min without loads.

2.12.7 Parallel connection of cables

2.12.7.1 Parallel connection of cables will be permitted only for cables having a cross-section of 10 mm² or more. The current-carrying capacity of cables connected in parallel is the sum of the current ratings of all



parallel conductors provided the cables have equal impedance, cross-section and rated maximum operating conductor temperatures.

2.12.8 Short-circuit capacity

2.12.8.1 Cables and their insulated conductors are to be capable of withstanding the mechanical and thermal effects of the maximum short-circuit.

2.12.9 Cable runs

2.12.9.1 Cable runs are to be, as far as possible, straight and accessible.

2.12.9.2 Cable runs are to be so arranged as to avoid the harmful effects from moisture or condensed water.

2.12.9.3 Cable runs are to be, as far as possible, remote from the sources of heat such as boilers, hot pipes, Resistors, etc., and are to be protected against mechanical damage.

2.12.9.4 Cables are not to be installed across expansion joints in the ships structure. Where it is unavoidable, a loop of cable having a length proportional to the expansion of the joint is to be provided. The minimum internal radius of the loop is to be at least 12 times the external diameter of the cable.

2.12.9.5 Cables having insulating materials with different maximum-rated conductor temperatures are not to be bunched together, or, where this is unavoidable, the cables are to be so operated that no cable reaches a temperature higher than that permitted for the lowest temperature-rated cable in the group.

2.12.9.6 Cables having a protective covering or sheathing which may damage the covering or sheathing of other cables are not to be bunched together.

2.12.9.7 Where a duplicate supply is required for essential electrical equipment, such as the two cables for the supply and control of the steering gear, the two cables are to follow different routes which are to be as far apart as practicable, both vertically and horizontally.

2.12.9.8 In the case of duplicated essential equipment, or systems which could operate as each others stand-by for an essential function (such as duplicated dynamic equipment of steering gears), the supply and any associated control cables are to follow different ways, which are to be arranged as far apart as practicable, both vertically and horizontally.

2.12.9.9 In a passenger ship, distribution systems are to be so arranged that fire in any main vertical zone as defined in these regulations will not interfere with services essential for safety in any other such zone. The requirement will be met if main and emergency feeders passing through any such zone are separated both vertically and horizontally as widely as is practicable.

2.12.9.10 Cables serving essential equipment or emergency power equipment, emergency lighting and intimal communications or signals used in an emergency are to be as far as practicable muted clear of galleys, laundries, machinery spaces and their casing and other high fire risk areas, except for supplying equipment in those spaces. Where possible, these cables are to be run in such a manner as to preclude their being rendered unserviceable by heating of the bulkheads that may be caused by a tire in an adjacent space.

2.12.9.11 Main cable runs and cables for the supply and control of essential services are to be kept away from the machinery, machinery part having an increased fire risk unless:

- a. The cables have to be connected to the subject equipment;
- b. The cables are separated by a steel bulkhead or deck from the subject equipment;
- c. The cables are of a fire-resisting type.

2.12.9.12 where trunk cables are laid in concealed manner, the panelling in way of which is to be arranged for easy removal.

2.12.9.13 Cables are not to be directly embedded in the thermal and sound insulation lagging made of combustible material.

Where the trunk cables are covered with non-combustible material for separation, they may be laid in the insulation lagging, but the load carried is to be reduced.

2.12.10 Measures to limit the propagation of fire along cable and wire bundles

2.12.10.1 Where bundled cable@ are individually flame-retardant and have been passed the single flame-retardant test in accordance with the standards accepted by the Society (see 2.12.3.3), measures to limit the propagation of fire along cable and wire bundles required in 2.12.10.2 to 2.12.10.4 are to be taken.

2.12.10.2 Fire stops are to be provided (see Fig. 2.12.10.2).

- a. Cables laid vertically in the closed or semi-enclosed moms are to be provided with fire stops in the following locations:
 1. Except cables installed within the fully-closed trunking, at every second deck or with a interval of 6 m;
 2. At cable entrances of main switchboard and emergency switchboard;
 3. At cable entrances of engine control room;
 4. At cable entrances of centralized control screen for propulsion machinery and essential auxiliary machinery;
 5. At each end of the fully-closed cable passageways.
- b. Cables laid horizontally in the closed or semi-enclosed moms am to be provided with fire stops in the same locations required in (a), but the maximum interval of fire stops may be increased to 14 m.

- c. Fire stops can only be fitted on the boundaries of compartments in the passageways of cargo holds and cargo areas with the height below the part of person's neck.

2.12.10.3 The fire dampers are designed in such a way as to meet the following requirements:

- a. The fire resistance of cable passing through fire stops must meet the requirements for class B-O divisions;
- b. Fire dampers are to be made of steel plate with the thickness of at least 3 mm;
- c. Where cable laid vertically in non-fully-closed trunking, the area of fire dampers is to cover the section area of the trunking;
- d. Where cable laid open, the fire dampers are to extend around to twice of the maximum size of cable, but not extend to penetrate the ceilings, decks, bulkheads or the rigid sidewall of trunkings.

2.12.10.4 Instead of the fire stops required above, installed cable bundles may be provided with flameproof coatings:

- a. For every 14 m on horizontal cable runs, over a length of 1 m, (see Fig. 2.12.10.4);
- b. Over the entire length of vertical cable runs (see Fig. 2.12.10.4).

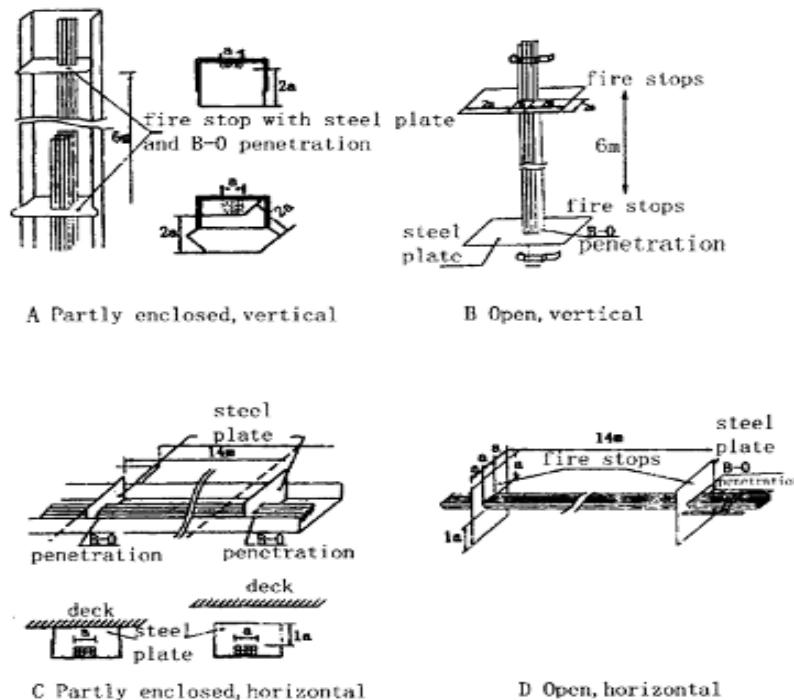

Fig 2.12.10.2 Locations of fire dampers

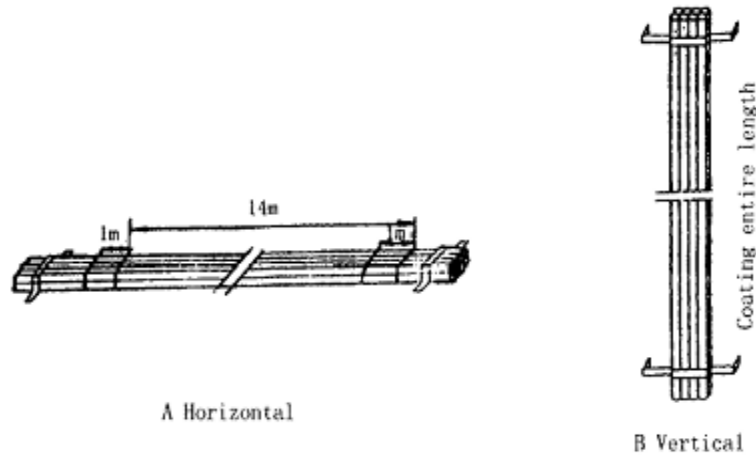

Fig 2.12.10.4 Location of flameproof coatings

2.12.11 Mechanical protection of cables

2.12.11.1 Cables exposed to risk of mechanical damage are to be protected by metal channels or casing or enclosed in steel conduit unless the protective covering of cables is sufficient to withstand the possible damage.

2.12.11.2 Cables in cargo holds and other spaces where there is exceptional risk of mechanical damage are to be suitably protected, even if armoured.

2.12.11.3 Metal casings for mechanical protection of cables are to be efficiently protected against corrosion.

2.12.11.4 Where cables are placed underneath the floor plates in machinery spaces, reliable precautions are to be taken to prevent such cables from being soaked in oil or water, or being exposed to mechanical damage.

2.12.12 Radius of bend

2.12.12.1 The minimum internal radius of bend of installed cables is to be generally in accordance with Table 2.12.12.1.

Table 2.12.12.1
Minimum internal radius of bends in cables for fixed wiring

Cable construction		Overall diameter of cable D (mm)	Minimum internal radius of bend F
Insulation	Outer covering		
Thermoplastics or thermoset material (copper conductor is in circle-type)	No armoured or no braided	≤25	4D
		>25	6D
	Metal sheathed braided or armoured	Any	6D
	Metal thread armoured, metal strip armoured or metal sheathed	Any	6D
	Synthetic polyester/ metal sheathed slice or combined sheathed	Any	8D
Thermoplastics or thermoset material (copper conductor is of specific type)	Any	Any	8D
Mineral	Hand metal sheathed	Any	6D

2.12.13 Securing of cables

2.12.13.1 Cables are to be effectively supported and secured with the exception of cables for portable appliances and of those installed in pipes, conduits, trunking or special casings.

2.12.13.2 Clips or straps are to be robust and are to have a sufficient surface area and shape that the cables may remain tight without their coverings or sheathing being damaged.

2.12.13.3 Clips, supports and accessories are to be made of corrosion-resistant material or suitably corrosion inhibited before erection.

2.12.13.4 The distance between supports is to be suitably chosen according to the type of cable and the possible vibration, and is generally to be in accordance with Table 2.12.13.4

Table 2.12.13.4
External diameter of cable and distance between supports (mm)

External diameter of cable (mm)		Distance between supports (mm)	
Exceeding	Not exceeding	Non-armoured cables	Armoured cables
–	8	200	250
8	13	250	300
13	20	300	350
20	30	350	400
30	–	400	450

2.12.14 Penetration of bulkheads and decks by cables

2.12.14.1 Penetration of watertight bulkheads or decks is to be carried out with either individual watertight glands or with packed watertight boxes carrying several cables. However, the watertight integrity of the bulkheads or decks is to be maintained.

2.12.14.2 Where cables pass through non-watertight bulkheads or structural steel, the holes are to be bushed with lead or other approved material. If the steel is 6 mm or more in thickness, adequately rounded edges may be accepted as the equivalent of bushing.

2.12.14.3 Penetration of bulkheads and decks which is required to have some degree of fire integrity is to be so effected as to ensure that the required degree of fire integrity is not unpaired.

2.12.14.4 Cables passing through decks are to be protected by deck tubes or ducts.

2.12.14.5 Materials used for glands and bushings are to be such that there is no risk of corrosion to cables or hull structures.

2.12.14.6 Where rectangular holes are cut in bulkheads or structural steel, the comers are to be radiused.

2.12.15 Installation of cables in pipes, conduits or trunking

2.12.15.1 When cables are installed in metal tubes, conduits or trunking, the following requirements are to be complied with:

- a. The internal surfaces of the pipes, conduits or trunking are to be smooth on the interior and protected against corrosion.
- b. Provision is to be made at the ends of pipes, conduits or trunking so as to protect the sheathing or covering of cables from being damaged.

- c. The pipes or conduits are to have such internal dimensions and radius of bend as will permit easy drawing in and out of the cables which they are to contain. The internal radius of bend is not to be less than that laid down for cables, provided that for pipes equal to or above 63 mm in external diameter, the internal radius of bend is not less than twice the external diameter of the pipe.
- d. The drawing-in factor (ratio of the sum of the cross-sectional areas of the cables to the internal cross-sectional area of the pipe) is not to exceed 0.4.
- e. Pipes, conduits or trunking are to be earthed and are to be mechanically and electrically continuous across joints.
- f. Pipes, conduits or trunking are to be so arranged that water cannot accumulate inside them (consideration being given to possible condensation).
- g. If necessary, ventilating openings are to be provided, preferably at the highest and lowest points, so as to permit air circulation and to prevent the accumulation of water at any part of the pipes, conduits or trunking. This may be done only if the fire-risk will not be increased thereby.
- h. Expansion joints are to be provided where necessary for long pipe run.
- i. Lead-sheathed cables without any coverings are not to be laid in pipes, conduits or trunking.

2.12.15.2 Where cables are laid in trunks, the trunks are to be so constructed as not to afford passage for fire from one tween-decks or compartment to another.

2.12.15.3 Cables used for cold cathode luminous discharge lamps are not to be installed in metal conduit unless protected by metal sheath or screen.

2.12.16 Installation of cables in refrigerated spaces

2.12.16.1 Cables not serving the refrigerated spaces are not to pass through such spaces. Cables installed in refrigerated spaces are to have a watertight or impervious sheath and are to be protected against mechanical damage. If an armoured cable is used, the armour, unless galvanized, is to be protected against corrosion by a further moisture-resisting covering.

2.12.16.2 Cables installed in refrigerated spaces are to be of open manner.

2.12.16.3 Where it is necessary for the cables to pass through the insulation lagging in the refrigerated spaces, they are to pass directly through at right angles and are to be protected by a metal tube sealed watertight at each end.

2.12.16.4 Metal supports used for securing the cables are to be galvanized or otherwise protected against corrosion.

2.12.16.5 Precautions are to be taken to prevent the placing of hooks round the cable as a casual means of suspension.

2.12.16.6 PVC insulated cables are generally not to be used in refrigerated spaces unless the PVC compounds are appropriate to low temperature service.

2.12.17 Relief of tension

2.12.17.1 Cables are to be so installed that the tension stress applied to them either by reason of their own weight or for any other reason is minimized. This is particularly important for cables of small cross-sections and for cables laid vertically or in vertical pipes.

2.12.18 Electrodynamic forces

2.12.18.1 In order to guard against the effects of electrodynamic forces in the event of short-circuit, single-core cables are to be firmly fixed and the strength of supports is to be sufficient to withstand the electrodynamic forces corresponding to the prospective short-circuit currents.

2.12.19 Installation of single-core cables for alternating current

2.12.19.1 A.C. power systems are, as far as practicable, to adopt the two-core or multi-core cables. Where it is necessary to use single-core cables for circuits rated in excess of 20 A, the following requirements are to be complied with:

- a. Cables are to be either non-armoured or armoured with non-magnetic material
- b. Cables belonging to the same circuit are to be contained in the same pipe, conduit or trunking. Cable clips are to include cables of all phases of a circuit, unless the clips are of non-magnetic material.
- c. In the installation of two, three or four single-core cables forming respectively single-phase circuits, three-phase circuits, or three-phase and neutral circuits, the cables are to be as far as possible in contact with one another. In any event, the distance between adjacent cables is not to be greater than one diameter.
- d. When single-core cables of current rating greater than 250 A are run along a steel bulkhead, the clearance between the cables and the bulkhead is to be at least 50 mm, unless the single-core cables belonging to different phases are installed in trefoil formation.
- e. Magnetic material is not to be placed between single-core cables of a group of the same circuit. If these cables pass through steel plates, all cables of the same circuit are to pass through a plate or gland so constructed that there is no magnetic material between the cables, and the clearance between the cable core and magnetic material is not to be less than 75 mm, unless single-core cables belonging to different phases are installed in trefoil formation.
- f. In order to equalize to some degree the impedance of three-phase circuits of considerable length consisting of single-core cables having a cross sectional area of 185 mm² or over, the phases are to be transposed at regular intervals of not exceeding 1.5 m. Alternatively, the three single-core cables of different phases may be installed in a trefoil formation. The above precautions are, however, not necessary when the length of the run is less than 30 m.

- g. In circuits involving several single-core cables in parallel per phase, each cable is to follow the same route and have the same cross-sectional area. Further, in order to avoid unequal division of the current, cables pertaining to the same phase are, as far as practicable, to be alternated with those of other phases. For instance, in case of six cables per phase, the correct dispositions are as shown in Table 2.12.19.1.
- h. The metal sheaths or coverings of single-core cables are to be earthed at one point only.

Table 2.12.19.1
Dispositions of cables

Cables in parallel per phase	1-Layer disposition	2-Layer disposition
2	ABC CBA	ABC CBA
3		ABCA BCABC
4		ABCABC CBACBA
5		ABCABCA BCABCABC
6		ABCABCABC CBACBACBA

2.12.20 Cables installation with respect to prevention of electromagnetic interface

2.12.20.1 In order to minimize the effects of unwanted electromagnetic interface, cables are to be installed in accordance with the relevant standards accepted by the Society.

2.12.21 Earthing of metal sheathings or coverings

2.12.21.1 Earthing of metal sheathings or coverings is to be in accordance with the relevant requirements of 1.3.

2.12.22 Cable ends

2.12.22.1 The ends of all conductors of cross-sectional area greater than 4 mm* are to be fitted with soldering sockets, compression type sockets or mechanical clamps. Corrosive fluxes are not to be used.

2.12.22.2 The temperature of cable sockets and connecting terminals is, in general, not to exceed the maximum working temperature for the cable in relation to the insulation.

2.12.22.3 Cables with a supplementary insulating belt beneath the protective sheath are to have additional insulation at those points where the insulation of each core makes or may make contact with earthed metal.

2.12.22.4 The fixing of conductors in terminals at joints and at tappings is to be capable of withstanding the thermal and dynamic effects of short-circuit currents.

2.12.22.5 The ends of mineral insulated cables are to be prepared in accordance with the instructions issued by the manufacturers of these cables.

2.12.22.6 Cables having a hygroscopic insulation (e.g. mineral insulated) are to have their ends sealed against ingress of moisture.

2.12.23 Joints and tappings

2.12.23.1 Cable runs are normally not to include joints. If, in the case of repair or sectional construction of the ship, a joint is necessary, the joint is to be of such a type that electrical continuity, insulation, mechanical strength and protection, earthing and fire-resisting or flame-retardant characteristics are not to be less than those required for the cables.

2.12.23.2 Tappings are to be made in suitable boxes, which are to be of such design that the conductors remain suitably insulated and protected from atmospheric action, and fitted with terminals or busbars of dimensions appropriate to the current rating.

2.12.23.3 Joints and tappings are to be clearly marked.

2.12.24 Joint boxes

2.12.24.1 Joint boxes are to be made of flame-retardant material. Live parts are to be mounted on durable flame-retardant moisture-resistant material, of permanently high dielectric strength and high insulation resistance.

2.12.24.2 The live parts are to be so arranged by suitable spacing or shielding with flame-retardant insulating material, that a short-circuit cannot readily occur between conductors of different polarity or between conductors and earthed metal.

2.12.24.3 All joint boxes are to be provided with durable labels bearing clearly the purposes and the circuit designations corresponding to the wiring diagrams. Where the joint boxes are installed in concealed manner, the panelling in way of the joint boxes is to be arranged for easy removal.

2.12.25 Cable trays/protective casings made of plastics materials

2.12.25.1 Cable trays/protective casings made of plastics materials are to be type tested in accordance with the type approval procedure applied by the Society.

2.12.25.2 Cable trays/protective casings made of plastics materials are to be supplemented by metallic fixing and straps such that in the event of a fire they, and the cables affixed, are prevented from falling and causing an injury to personnel and/or an obstruction to any escape route. When plastics cable trays/protective casings are used on open deck, they are additionally to be protected against UV light.

2.12.25.3 The load on the cable trays/protective casings is to be within the Safe Working Load (SWL). The support spacing is not to be greater than the Manufacturer's recommendation nor in excess of spacing at the SWL test. In general the spacing is not to exceed 2 m. The selection and spacing of cable tray/protective casing supports are to take into account:

- a. Cable trays/protective casings' dimensions;
- b. Mechanical and physical properties of their material;
- c. Mass of cable trays/protective casings;
- d. Weight of cables, external forces, thrust forces and vibrations;
- e. Maximum accelerations to which the system may be subjected;
- f. Combination of loads.

2.12.25.4 The sum of the cables' total cross-sectional area, based on the cables' external diameter, is not to exceed 40% of the protective casing's internal cross-sectional area. This does not apply to a single cable in a protective casing.

2.13 LIGHTNING CONDUCTORS

2.13.1 Protection against primary structural damage

2.13.1.1 A lightning conductor need not be fitted to a ship of metallic construction where a low resistance path to earth will be inherently provided by masts, structural members and the hull.

2.13.1.2 A lightning conductor is to be fitted to a ship with many non-metallic structural members.

2.13.1.3 The lightning conductor is comprised of air terminal, down conductor and earth termination.

2.13.1.4 Metallic masts and metallic structural members may form part or all of any lightning conductor.

2.13.1.5 The metal rigging, such as stays, shrouds, etc., are to be bonded to the lightning conductor.

2.13.1.6 Joints in down conductors are to be accessible and be located or protected so as to minimize accidental damage. They are to be made by means of copper rivets or clamps. Clamps may be of copper or

of copper alloy and are to preferably be of the serrated contact type and effectively locked. No connection is to be dependent on a soldered joint.

2.13.1.7 The resistance between air terminals and earth terminations is not to exceed 0.02.

2.13.1.8 Suitable means are to be provided to enable ships when in dry dock, or on a slipway, to have their lightning conductor or metal hull connected to an efficient earth on shore. Connecting cables to the shore earth is to be external to the earth throughout their length.

2.13.1.9 Air terminals of the lightning conductor are to comply with the following requirements:

- a. An air terminal is to be fitted to each non-metallic mast.
- b. Air terminals are to be made of copper or copper alloy conducting bar of not less than 12 mm diameter, and are to project at least 300 mm beyond the top of the mast. Other materials may be used, for example stainless steel or aluminium alloys, or steel bar effectively protected against corrosion, subject to the requirements of 2.13.1.7. The material is to be resistant to sea water.
- c. Vent outlets for flammable gases located at or near the top of masts on tank ships are to be protected by air terminals which extend at least 2 m above the vent outlet, a steel mast may serve as the air terminal if it extends 2 m above the outlet.

2.13.1.10 the down conductors are to comply with the following requirements:

- a. Down conductors are to be made of copper, or copper alloy tape or cable. Cable is preferred as both the insulation and the circuit shape inhibit surface discharge. Other materials may be used, for example stainless steel or aluminium alloys, subject to the requirements of 2.13.1.7. The material is to be resistant to sea water.
- b. Down conductors of copper are to have a minimum cross-section of 70 mm², be firmly secured to the structure and be run as straight as possible between the air terminal and the earth termination. Bends, where necessary, are to have a minimum radius of at least 10 times the equivalent diameter of the conductor.

2.13.1.11 The ends of down conductors are to be reliably bonded to the earth terminations of the metallic construction of ship nearby. Where necessary, measures are to be taken for preventing electrochemical corrosion.

2.13.2 Protection against secondary damage

2.13.2.1 On all ships, equipment is to be so installed as to minimize the effect of secondary damage to the electrical system caused by lightning.

2.13.2.2 Metallic enclosures are to be reliably earthed. Particular attention is to be paid to navigation lights and other equipment at the top of masts and on other elevated structures.

2.13.2.3 Cable screens or armour, though normally earthed for signal interference suppression, are not to provide the sole lightning path for equipment. Separate earthing, as required in 2.13.2.2, is to be provided.

2.13.2.4 The formation of cable loops, or metallic loops such as pipework, in proximity to down conductors of lightning conductor required in 2.13.1.2 is to be avoided. Cables in close proximity to down conductors are to be installed in metal pipes.

2.13.2.5 Cables along decks are to be installed close to the deck and advantages are to be taken of the screening effect of earthed metallic structures near to or above the cable runs, for examples handrails, pipes, etc.

2.13.2.6 Means are to be provided for the discharging to earth of any lightning energy that may be induced in for example radio and navigational equipment antennas. Consideration is to be given to installing devices such as spark gaps or surge diverters to provide protection from voltage transients.

2.14 SPECIAL REQUIREMENTS FOR HIGH VOLTAGE ELECTRICAL INSTALLATIONS

2.14.1 General requirements

2.14.1.1 This Section applies to a.c. three-phase systems with nominal voltage exceeding 1 kV. If not otherwise stated herein, construction and installation applicable to low voltage equipment generally apply to high voltage equipment.

2.14.1.2 The nominal system voltage is not to exceed 15 kV. Where necessary for special application, higher voltages may be accepted by the Society.

2.14.1.3 Equipment with voltage above about 1 kV is not to be installed in the same enclosure as low voltage equipment, unless segregation or other suitable measures are taken to ensure that access to low voltage equipment is obtained without danger.

2.14.2 System design

2.14.2.1 The distribution of high-voltage electrical installations is to comply with the following:

- a. It is to be possible to split the main switchboard into at least two independent sections, by means of at least one circuit breaker or other suitable disconnecting devices, each supplied by at least one generator. If two separate switchboards are provided and interconnected with cables, a circuit breaker is to be provided at each end of the cable.
Services which are duplicated are to be divided between the sections.
- b. For earthed neutral systems, in case of earth fault, the current is not to be greater than full load current of the largest generator on the switchboard or relevant switchboard section and not less than three times the minimum current required to operate any device against earth fault.

It is to be assured that at least one source neutral to ground connection is available whenever the system is in the energised mode. Electrical equipment in directly earthed neutral or other neutral earthed systems is to withstand the current due to a single phase fault against earth for the time necessary to trip the protection device.

- c. Means of disconnection are to be fitted in the neutral earthing connection of each generator so that the generator may be disconnected for maintenance and for insulation resistance measurement.
- d. All earthing impedances are to be connected to the hull. The connection to the hull is to be so arranged that any circulating currents in the earth connections do not interfere with radio, radar, communication and control equipment circuits.
- e. In the systems with neutral earthed, connection of the neutral to the hull is to be provided for each section.

2.14.2.2 Each part of the electrical installation is to be provided with a degree of protection appropriate to the location, as a minimum the requirements of Table 1.3.2.2, and to satisfy the following:

- a. The degree of protection of enclosures of rotating electrical machines is to be at least IP23. The degree of protection of terminals is to be at least IP44. For motors installed in spaces accessible to unqualified personnel, a degree of protection against approaching or contact with live or moving parts of at least IP4X is required;
- b. The degree of protection of enclosures of transformers is to be at least IP23. For transformers installed in spaces accessible to unqualified personnel, a degree of protection of at least IP4X is required.
For transformers not contained in enclosures, 2.14.7.1 is to be complied with.
- c. The degree of protection of metal enclosed switchgear, controlgear assemblies and static convertors is to be at least IP32. For switchgear, control gear assemblies and static converters installed in spaces accessible to unqualified personnel, a degree of protection of at least IP4X is required.

2.14.2.3 The air clearances and creepage distances are to comply with the following:

- a. In general, for non type tested equipment phase-to-phase air clearances and phase-to-earth air clearances between non-insulated parts are to be not less than those specified in Table 2.14.2.3.

Table 2.14.2.3
Minimum air clearance

Nominal voltage (KV)	Minimum air clearance (mm)
3 (3.3)	55
6 (6.6)	90
10 (11)	120
15	160

Intermediate values may be accepted for nominal voltages provided that the next higher air clearance is observed. In the case of smaller clearances, appropriate voltage impulse test must be applied.

- b. Creepage distances between live parts and between live parts and earthed metal parts for standard components are to be in accordance with relevant IEC publications for the nominal voltage of the system, the nature of the insulation material and the transient overvoltage developed by switch and fault conditions.

For non-standardised parts within the busbar section of a switchgear assembly, the minimum creepage distance is to be at least 25 mm/kV and behind current limiting devices, 16mm/kV.

2.14.2.4 For protection of the high-voltage electrical system, the following special requirements are to be complied with:

- a. Protective devices are to be provided against phase-to-phase faults in the cables connecting the generators to the main switchboard and against interwinding faults within the generators.
The protective devices are to trip the generator circuit breaker and to automatically de-excite the generator.
In distribution systems with a neutral earthed, phase to earth faults are also to be treated as above.
- b. Any earth fault in the system is to be indicated by means of a visual and audible alarm. In low impedance or direct earthed systems (a system is defined effectively earthed when earthing factor is lower than 0.8) provision is to be made to automatically disconnect the faulty circuits. In high impedance earthed systems (a system is defined non-effectively earthed when earthing factor is higher than 0.8), where outgoing feeders will not be isolated in case of an earth fault, the insulation of the equipment is to be designed for the phase to phase voltage.
- c. Power transformers are to be provided with overload and short circuit protection. When transformers are connected in parallel, tripping of the protective devices at the primary side has to automatically trip the switch connected at the secondary side.
- d. Voltage transformers are to be provided with overload and short circuit protection on the secondary side.
- e. Fuses are not to be used for overload protection.
- f. Lower voltage systems supplied through transformers from high voltage systems are to be protected against overvoltages. This may be achieved by:
 - 1. Direct earthing of the lower voltage system;
 - 2. Appropriate neutral voltage limiters;
 - 3. Earthed screen between the primary and secondary windings of transformers.

2.14.3 Rotating machinery

2.14.3.1 Generator stator windings are to have all phase ends brought out for the installation of the differential protection.

2.14.3.2 Rotating machinery is to be provided with temperature detectors in their stator windings to actuate a visual and audible alarm in a normally attended position whenever the temperature exceeds the permissible limit.

If embedded temperature detectors are used, means are to be provided to protect the circuit against overvoltage.

2.14.3.3 In addition to the tests normally required for rotating machinery, a high frequency high voltage test in accordance with standard(s) acceptable to the Society is to be carried out on the individual coils in order to demonstrate a satisfactory withstand level of the inter-turn insulation to steep fronted switching surges.

2.14.4 Power transformers

2.14.4.1 Dry type transformers are to comply with standard(s) acceptable to the Society, and liquid cooled transformers are also to comply with standard(s) acceptable to the Society.

2.14.4.2 Oil immersed transformers are to be provided with the following alarms and protections:

- a. liquid level (Low) – alarm;
- b. liquid temperature (High) – alarm;
- c. liquid level (Low) - trip or load reduction;
- d. liquid temperature (High) - trip or load reduction;
- e. gas pressure relay (High) - trip.

2.14.5 Cables

2.14.5.1 Cables are to be constructed in accordance with standard(s) acceptable to the Society.

2.14.6 Switchgear and controlgear assemblies

2.14.6.1 Switchgear and controlgear assemblies are to be manufactured in accordance with standard(s) acceptable to the Society.

2.14.6.2 Switchgear and controlgear assemblies are to be constructed in accordance with the following requirements:

- a. Switchgear is to be of metal - enclosed type or of the insulation - enclosed type in accordance with standard(s) acceptable to the Society.
- b. Withdrawable circuit breakers and switches are to be provided with mechanical locking facilities in both service and disconnected positions. For maintenance purposes, key locking of withdrawable circuit breakers and switches and fixed disconnectors is to be possible.

Withdrawable circuit breakers are to be located in the service position so that there is no relative motion between fixed and moving portions.

- c. The fixed contacts of withdrawable circuit breakers and switches are to be so arranged that in the withdrawable position the live contacts are automatically covered.
- d. For maintenance purposes an adequate number of earthing and short-circuiting devices is to be provided to enable circuits to be worked upon with safety.

2.14.6.3 Requirements for auxiliary systems

- a. If electrical energy and/or physical energy is required for the operation of circuit breakers and switches, a store supply of such energy is to be provided for at least two operations of all the components.

However, the tripping due to overload or short-circuit, and under-voltage is to be independent of any stored electrical energy sources. This does not preclude shunt tripping provided that alarms are activated upon lack of continuity in the release circuits and power supply failures.

- b. At least one independent source of supply for auxiliary circuits of each independent section of the system (see 2.14.2.1(a) of this Section) is to be provided. Where necessary, one source of supply is to be from the emergency source of electrical power for the start up from dead ship condition.

2.14.6.4 A power-frequency voltage test is to be carried out on any switchgear and controlgear assemblies. The test procedure and voltages are to be according to standard(s) acceptable to the Society.

2.14.7 Installation

2.14.7.1 Where equipment is not contained in an enclosure but a room forms the enclosure of the equipment, the access doors are to be so interlocked that they cannot be opened until the supply is isolated and the equipment earthed down.

At the entrance of the spaces where high-voltage electrical equipment is installed, a suitable marking is to be placed which indicates danger of high-voltage. As regards the high-voltage electrical equipment installed outside a.m. spaces, the similar marking is to be provided.

2.14.7.2 Run of high-voltage cables is to comply with the following:

- a. In accommodation spaces, high voltage cables are to be run in enclosed cable transit systems;
- b. High voltage cables are to be segregated from cables operating at different voltage ratings each other; in particular, they are not to be run in the same cable bunch, nor in the same ducts or pipes, or, in the same box.

Where high voltage cables of different voltage ratings are installed on the same cable tray, the air clearance between cables is not to be less than the minimum air clearance for the higher voltage side in 2.14.2.3(a). However, high voltage cables are not to be installed on the same cable tray for the cables operating at the nominal system voltage of 1 kV and less.

- c. High-voltage cables, in general, are to be installed on carrier plating when they are provided with a continuous metallic sheath or armour which is effectively bonded to earth; otherwise they are to be installed for their entire length in metallic castings effectively bonded to earth.

- d. Terminations in all conductors of high voltage cables are to be, as far as practicable, effectively covered with suitable insulating material. In terminal boxes, if conductors are not insulated, phases are to be separated from earth and from each other by substantial barriers of suitable insulating materials. High voltage cables of the radial field type, i.e. having a conductive layer to control the electric field within the insulation, are to have terminations which provide electric stress control. Terminations are to be of a type compatible with the insulation and jacket material of the cable and are to be provided with means to ground all metallic shielding components (i.e. tapes, wires etc.).
- e. High-voltage cables are to be readily identifiable by suitable marking.
- f. Before a new high voltage cable installation, or an addition to an existing installation, is put into service a voltage withstand test is to be satisfactorily carried out on each completed cable and its accessories. The test is to be carried out after an insulation resistance test and in accordance with standard(s) acceptable to the Society or the following:
 - 1. When a d.c. voltage withstand test is carried out, the voltage is to be not less than: $1.6 (2.5 U_0 + 2kV)$ for cables of rated voltage (U_0) up to and including 3.6 kV, or $4.2 U_0$ for higher rated voltages where U_0 is the rated power frequency voltage between conductor and earth or metallic screen, for which the cable is designed. The test voltage is to be maintained for a minimum of 15 minutes. After completion of the test the conductors are to be connected to earth for a sufficient period in order to remove any trapped electric charge. An insulation resistance test is then repeated.
 - 2. When an a.c. voltage withstand test is carried out, the voltage is to be not less than normal operating voltage of the cable and it is to be maintained for a minimum of 24 hours.

2.15 ADDITIONAL REQUIREMENTS FOR ELECTRICAL PROPULSION INSTALLATIONS

2.15.1 General requirements

2.15.1.1 The electrical propulsion installations are to meet the requirements of this Section and also the applicable provisions of this PART.

2.15.1.2 The normal torque available in the propulsion motors for manoeuvring is to be capable of stopping or reversing the ship in a reasonable time under the maximum service speed of the ship.

2.15.1.3 Adequate torque margin is to be provided in A. C. propulsion systems to guard against the motor from being pulled out of synchronism during rough weather or during turning in the case of multiple-screw ships.

2.15.1.4 The lubrication of the bearing of propulsion motors, gearing and shafting is to be effective at all normal speeds from creep speeds upwards, either ahead or astern.

The above shafts and bearings are not to be damaged by slow rotation, whether or not electrical power is applied to the motor or whether such rotation is induced by the propellers and under all predictable oil temperature conditions.

2.15.1.5 The power source of propulsion system may be supplied by the generator sets specially for propulsion, it may also be supplied by a public power station for propulsion and daily loading.

2.15.1.6 The public power station is to meet the following requirements:

- a. The control system of the station is to ensure the safety distribution between propulsion and daily loading, where necessary, means am to be taken to discharge non-essential loading and/or reduce the propulsion power.
- b. Where one generator set is out of order, the remains am to be capable of supplying power to all essential equipment onboard ships and maintaining the effective propulsion simultaneously.
- c. Where power is supplied by two or above generator sets in parallel connection under normal conditions, the remains in operation are to ensure to enable the essential equipment to operate consecutively and to propel effectively in the event of a sudden power failure of one generator set.

2.15.2 Prime movers

2.15.2.1 Prime movers and their governors are to comply with the requirements of these regulations. The rated power in conjunction with the overloading and load built-up capabilities are to be adequate to supply the power needed during transitional changes under operating conditions of the electrical equipment due to manoeuvring and the heavy sea and weather conditions.

2.15.2.2 Where the speed control of the propeller requires speed variation of the prime mover, the governor is to permit a very gradual variation of speed within the necessary speed range and means are to be provided to enable local manual as well as remote control of the governor.

2.15.2.3 In the case of parallel operation of generators, the governing systems used are to permit stable operation to be maintained over the entire operational speed range of the prime movers.

2.15.2.4 During manoeuvring from full speed ahead to full speed astern with the ship making full way ahead, the prime-mover is to be capable of absorbing a proportion of the regenerated power without tripping due to overspeed.

2.15.2.5 The overspeed governor is to be set to a speed in excess of the highest possible speed during the periods of power regeneration, and the generating set including prime mover is to be so designed that no damage will be raised from an overspeed equal to that at which the governor is set.

2.15.3 Rotating machines

2.15.3.1 Variable speed rotating machines fitted with an integral fan are to be capable of operation at speeds below the rated speed range under full-load torque, full-load current and full-load excitation or similar operating conditions, with the temperature rise not exceeding the limits as given in Table 4.1.2.1.

2.15.3.2 The temperature of the cooling air of machines provided with forced air ventilation (air ducts or air filters) is to be continuously monitored by means of direct reading thermometers which are readable from outside the machine and a remote audible alarm actuated by suitable temperature detectors.

2.15.3.3 For machines fitted with heat exchangers with a closed circuit method of cooling, the flow of primary and secondary coolants is to be monitored. Alternatively, monitoring of winding temperatures plus alarms may be accepted in lieu of the flow monitoring. And in addition, consideration is to be given, where necessary, to the provision of devices for detecting leakage of cooling liquid in the machine enclosure and the operation of an associated alarm.

2.15.3.4 The collector rings and commutators are to be suitably arranged for easy maintenance. For the purpose of inspection, repair, withdrawal and replacement of the field coils, provision is to be made for easy access to all windings and bearings.

2.15.3.5 Effective means are to be provided for the rotating machines to prevent accumulation of moisture and condensation when they are idle. If steam is used for heating purpose, no joints of steam pipes are permitted within the machines.

2.15.3.6 A.C. machines are to be capable of withstanding a sudden short circuit at their terminals under rated operating conditions without suffering damages.

2.15.3.7 Stator windings of A.C. Machines and interpole windings of D. C. Machines, all rated above 500 kW, are to be provided with temperature sensors.

2.15.4 Excitation

2.15.4.1 The obtainable current and voltage of exciters and their supply are to be suitable for the output required during manoeuvring and overcurrent conditions including short-circuit. For this reason, attention is to be paid to the strength of shafts and couplings of rotating sets and to the power of their driving machines.

2.15.4.2 If a propulsion system contains only one generator and one motor and cannot be connected to another propulsion system, more than one exciter set is to be provided for each machine. However, this requirement is not necessary for self-excited generators or for multi-propeller propulsion ships where any additional exciter set may be common for the ship.

2.15.4.3 The ship's main source of electrical power may be accepted as one means of excitation. In this case, the power supply is to be fed directly from the main switchboard and protected against short-circuit only.

2.15.4.4 Field circuits are to be provided with means for suppressing voltage rise when a field switch is opened.

2.15.4.5 For Ward-Leonard systems, arrangements for generator and motor excitation are to be such that if the motor excitation circuit is opened by a switch or contactor, the generator excitation circuit is simultaneously interrupted, or the generator voltage is immediately reduced to zero.

2.15.4.6 In constant voltage systems with two or more independently controlled motors in parallel on the same generator(s), the armature circuit-breaker is to be tripped when an excitation circuit is opened by a switch or contactor.

2.15.4.7 Where fuses are used for excitation circuit protection, it is essential that they do not interrupt the field discharge resistor circuit upon rupturing.

2.15.5 Controlgear

2.15.5.1 Control of the propulsion machines may be carried out from the bridge or deck. Alternative control in the engine room is to be provided. Transfer of control to the engine room in an emergency is to be possible and to be carried out in the engine room.

2.15.5.2 Either manual operation or operation with the aid of power or a combination of both may be used. In case of manual operation, all manoeuvring switches, field-regulators and controllers are to be operable without undue manual effort.

If failure of the power supply occurs in systems with power-aided control (e. g. with electrical, pneumatic or hydraulic aid), the control of any such device is to be capable of being restored by other suitable means in a short time.

2.15.5.3 When two or more control stations are provided, a selector switch or other means is to be provided for transferring the manoeuvring controls to the designated station. Simultaneous control from more than one control station is not to be possible. Provision is to be made to prevent malfunction due to the transferring of the control stations. In addition, indication is to be located at each control to indicate which station is in control.

2.15.5.4 Levers for operating contactors, line switches, field switches are to be interlocked to prevent incorrect switching. These interlocks are to be of mechanical type as far as practicable.

2.15.5.5 The reference value transmitters in the control stations and the control equipment are to be so designed that a failure in the desired value transmitters or in the cables between the control station and the propulsion system will not cause a substantial increase in the propeller speed.

2.15.5.6 Measures are to be taken that the control of the propulsion system can be activated only when the designated control lever is in zero position and the system is ready for operation.

2.15.5.7 Each control station is to have an emergency stop device which is independent of the control lever.

2.15.6 Cables

2.15.6.1 The conductors of cables external to the components of the propulsion plant, other than cables and interconnecting wiring for computers, data loggers or other automation equipment requiring currents of very small value, are to consist of not less than seven strands and have a cross-sectional area of not less than 1.5 mm².

2.15.7 Main circuits

2.15.7.1 Propulsion system having two or more generators, or two or more semiconductor converters, or two or more motors on one propeller shaft is to be so arranged that any unit of them can be taken out of service and isolated electrically without impairing the operation of the remaining machines.

2.15.8 Protection

2.15.8.1 Over-current protective devices, if fitted in the main circuits, are to be set sufficiently high so that there is no possibility of their operation due to the over-current caused by manoeuvring or normal operation in heavy seas, or in floating pack ice.

2.15.8.2 For D.C. Systems in which excessive over-speeding of the propulsion motors may occur (for example, at light loads or loss of a propeller), suitable over-speed protection is to be provided.

2.15.8.3 Where separately driven D. C. Generators are connected electrically in series, means is to be provided to prevent reversal of the rotation of a generator upon failure of the driving power of its prime-mover.

2.15.8.4 No over - load protection is to be provided in the excitation circuits to open the circuit.

2.15.8.5 Means are to be provided for discriminative tripping or rapid reduction of the magnetic fluxes of the generators or motors to ensure that over-currents do not reach the value which may endanger the plant.

2.15.8.6 In the case of A. C. three-phase propulsion systems, an imbalance protective device is to be provided, which may deexcite the propulsion generators and motors or disconnects the relevant circuits in the event of substantial difference of current in the various phases of the propulsion motors.

2.15.8.7 Means for earth leakage detection is to be provided for the main propulsion circuit, and be arranged to operate an alarm upon the occurrence of earth faults. Where the circulation of fault current is liable to cause damage, tripping arrangements are also to be provided.

2.15.8.8 Means are to be provided for earth leakage detection in the excitation circuits of propulsion machines but may be omitted in circuits of brushless excitation systems and machines rated up to 500 kW.

2.15.8.9 Consideration is to be given in the design of D.C. machines and their protective systems to measures necessary to minimize damage in the event of short-circuit.

2.15.8.10 If there is a possibility of blocking the propeller (e. g. during ice-breaking operation) , a protection against damage of the propulsion plant is to be provided.

2.15.9 Instrumentation

2.15.9.1 Measuring instruments fitted in the engine room control station are to comply with the requirements of 2.15.9.2 (for A.C. system) and 2.15.9.3 (for D.C. system).

At each control station other than the engine room control station, one speed indicator and other necessary instruments are to be installed at a conspicuous location near such a station.

2.15.9.2 A. C. Propulsion systems are at least to be provided with the instruments as given in Table 2.15.9.2.

**Table 2.15.9.2
Instruments for A.C. propulsion system**

Item	Instruments	Quantity	Remarks
For each propulsion generator	Ammeter Voltmeter Wattmeter Frequency meter Kilovarmeter Or field ammeter	1 1 1 1 1	If generators are to be operated in paral
For propulsion generators and motors rated above 500k W	Temperature indicator	1	Reading directly the temperature of the stator windings
For each propeller motor	Ammeter	1	
For each propulsion synchronous motor	Field ammeter	1	
For each propeller shaft	Speed indicator	1	
For each bridge connection of semiconductor converters	Ammeter	1	

2.15.9.3 D. C. propulsion systems arc at least to be provided with the instruments as given in Table 2.15.9.3.

Table 2.15.9.3
Instruments for D.C. propulsion system

Item	Instruments	Quantity	Remarks
For each propulsion generator	Ammeter Voltmeter Field ammeter	1	
For each propulsion motor	Field ammeter	1	
For the amature current of each motor	Ammeter	1	For propulsion motors fed from the main electrical system
For the amature voltage of each motor	Ammeter	1	For propulsion motors fed by semiconductor converters
For the amature current of each motor	Voltmeter	1	
For the amature voltage of each motor	Ammeter	1	
For excessive temperature of the interpole winding of motors rated above 500k W	High-temp. warning	1	
For each propeller shaft	Speed indicator	1	

2.16 ADDITIONAL REQUIREMENTS FOR OIL TANKERS

2.16.1 General requirements

2.16.1.1 The following distribution systems may be used in tankers:

- a. D.C., two-wire insulated;
- b. A.C., single-phase, two-wire insulated;
- c. A. C., three-phase, three-wire insulated.

2.16.1.2 No electrical connection is allowed between circuits having different voltages.

2.16.1.3 All circuits of generation, supply and distribution systems are not to be earthed, and hull return system is also not permitted with the following exceptions:

- a. Intrinsically safe circuits;
- b. Power supplied, control circuits and instrumentation circuits where technical or safety reasons preclude the use of a system with no connection to earth, provided the current in the hull is limited to not more than 5 amps in both normal and fault conditions;
- c. Limited and locally earthed systems, provided that any possible resulting current does not flow directly through any of the dangerous spaces;
- d. Alternating current power networks of 1000 V or more (line to line) and over, provided that any possible resulting current does not flow directly through any of the dangerous spaces.

2.16.1.4 All cables laid in the hazard areas are to be sheathed with at least one of the following:

- a. Non-metallic impervious sheath plus metal meshwork or other metallic cover;
- b. Copper or stainless sheath (only for mineral insulated cables).

2.16.1.5 Where corrosion may be expected, non-metallic impervious sheath is to be applied over the metal meshwork, metallic sheath or steel armour of the cable.

2.16.1.6 Electrical cables are not to be installed in dangerous zones or spaces, except as otherwise permitted in this Chapter, or when associated with intrinsically safe circuits.

2.16.1.7 Cables associated with intrinsically safe circuits are to be used only for such circuits. They are to be physically separated from cables associated with non-intrinsically safe circuits, e. g. neither led in the same casing or pipe, nor secured by the same fixing clip.

2.16.1.8 Where cables pass through gastight bulkheads or decks, separating dangerous zones or spaces from non-dangerous zones or spaces, arrangements are to be such that gastight integrity of the bulkhead or deck is not impaired.

2.16.1.9 Cables installed on deck or on fore and aft gangways are to be protected against mechanical damage. Cables are to be installed so as to avoid strain or chafing and due allowance is to be made for expansion or working of the structure. Where expansion bends are fitted, they are to be accessible for maintenance. (See also 2.16.2.3 (f) ②).

2.16.1.10 Cables installed in pump rooms are to be suitably protected against mechanical damage. (See also 2.16.2.3 (c) ④ of this Section).

2.16.1.11 Cable runs are to be kept at an adequate distance from the decks, bulkheads, cargo tanks or pipes. When cables pass through bulkheads, the distance of the cables from steam pipe flanges is to be not less

than 450 mm for steam pipes having a diameter greater than 75 mm, and not less than 300 mm for steam pipes having a diameter equal to or less than 75 mm.

2.16.1.12 Flexible cables or wires for portable electrical appliances are not to pass through the dangerous zones or spaces, with the exception of flexible cables or wires of intrinsically safe type.

2.16.1.13 a device is to be installed to continuously monitor the insulation level, particularly of circuits (other than intrinsically safe circuits) which pass through dangerous zones or spaces or which are connected to apparatus installed in such zones or spaces. The device is to operate an alarm in the event of an abnormally low level of insulation.

2.16.1.14 Measuring, monitoring, control and communication equipment (including pocket radio equipment) and circuits located in dangerous zones or spaces are to be intrinsically safe.

2.16.1.15 Transmitting aerials and any associated riggings are to be sited well clear of gas and vapour outlets.

2.16.1.16 when safe type equipment is permitted in dangerous zones, all switches and protective devices are to be capable of interrupting all lines or phases and are to be located in a non-dangerous zone or space. Such equipment, switches and protective devices are to be suitably labelled for identification purpose.

2.16.1.17 Portable lamps used in dangerous zones or spaces are to be:

- a. Of intrinsically safe, increased safety and flameproof type with self-contained battery;
- b. Of air driven type with pressurized enclosure.

2.16.1.18 Fixed lamps used in dangerous zones or spaces are to be:

- a. Of flameproof type;
- b. Of increased safety type;
- c. Of pressurized type.

2.16.1.19 the socket outlets and plugs installed in the extended dangerous zones or spaces on the weather deck are to be interlocked with a switch so that the plug cannot be inserted or withdrawn when the switch is in the on position, and the switch is to be capable of isolating all the poles or phases in the circuit.

2.16.1.20 Cargo tanks, process plant and piping systems are to be earthed in accordance with 1.3.4.12 for the control of static electricity.

2.16.1.21 All rigging of oil tankers is to be effectively bonded to ship's hull.

2.16.1.22 Decorative lighting is strictly prohibited in oil tankers.



2.16.2 Electrical equipment in dangerous zones or spaces of oil tankers carrying cargo oils having a flash point not exceeding 60 °C.

2.16.2.1 Electrical equipment and wiring are, in principle, not to be installed in any dangerous zones or spaces. If it is impracticable to avoid doing so, the certified safe type electrical equipment complying with 1.3.3 is to be adopted as appropriate.

2.16.2.2 Where certified safe type electrical equipment is used, the group and temperature class are not to be less than the requirements of IIA, T3.

2.16.2.3 Electrical equipment and cables permitted to be installed in dangerous zones or spaces:

- a. Cargo oil tanks: ia class intrinsically safe electrical equipment.
- b. Cofferdams, double bottom tanks, duct keels or tube tunnels adjoining cargo tanks:
 - 1. ia class intrinsically safe equipment;
 - 2. Flameproof type lighting fittings;
 - 3. Transducers of electrical depth-sounding devices. The transducers of electrical depth-sounding devices are to be hermetically enclosed and are to be installed in a gastight, robust vertical trunk located clear of the cargo tank bulkhead. Cables to the transducers are to be housed in pipes with gastight joints to the main deck. The cable pipe is to be sealed with packings where the cable passes a cofferdam;
 - 4. Where impressed current cathodic protection systems are fitted (for external hull protection only) and if it is essential for the cables to pass through cofferdams, these cables are to be installed in heavy gauge steel pipes with gastight joints up to the main deck. Corrosion-resistant pipes are to be used in compartments which may be filled with sea water (e. g. permanent ballast tanks).
- c. Cargo pump rooms:
 - 1. Electrical equipment as defined in 2.16.2.3 (b);
 - 2. ib class intrinsically safe equipment;
 - 3. Flameproof type lighting.
Flameproof type lighting points are to be arranged on two independent circuits with the lighting points distributed alternately so as to permit light from one circuit to be retained while maintenance is carried out on the other. The lighting in pump rooms is to be controlled by a separate control box located in non-dangerous spaces. Each sub-circuit is to be provided with an indicating lamp. The switches and protective devices are to be suitably labelled for identification purpose;
 - 4. Where it is necessary for cables, other than those supplying lighting to pump rooms, to pass through cargo pump room entrances, they are to be installed in heavy gauge steel pipes with gastight joints.
- d. Enclosed or semi-enclosed spaces immediately above cargo tanks (e. g. tweendeck spaces) or having bulkheads above and in line with cargo tank bulkheads, enclosed or semi-enclosed spaces immediately above cargo pump rooms or above vertical cofferdams adjoining cargo tanks, without

separation from each other by a gastight deck and without mechanical ventilation, and compartment for cargo hoses:

1. Intrinsically safe equipment;
 2. Lighting fitting as defined in 2.16.1.18;
 3. Through runs of cable.
- e. Spaces other than cofferdams adjoining to and below the top of a cargo oil tank, e.g. trunks, passageways and cargo holds:
1. Electrical equipment as defined in 2.16.2.3 (b);
 2. Through runs of cables, subject to agreement of the Society.
- f. Zones on weather deck, or semi-enclosed spaces on weather deck, within 3 m of any cargo oil tank outlet or vapour outlet (e.g. cargo tank hatches, sight ports, tank cleaning openings, loading/discharging connection joint of cargo oil, ullage openings, sounding pipes, cargo pump room entrances and cargo oil vapour outlet or vent for cargo pump room entrance, cofferdams and cargo tanks), cylindrical zone on weather deck with a radius of 10 m around and above the ventilation openings of breathing valve outlets of cargo tanks, and from there downward to the deck:
1. Certified safe type equipment suitable for use on the weather deck;
 2. Through runs of cables, but cable expansion bends are not to be used in this zone.
- g. Zones on weather deck over all cargo tanks (including all ballast tanks within the cargo tank area) to the full width of the vessel, plus 3 m fore and aft on weather deck, up to a height of 2.4 m above the deck, enclosed or semi-enclosed spaces having direct openings to any of the above spaces:
1. Certified safe type equipment and such equipment is to be suitable for use on weather deck, where necessary;
 2. Through runs of cables.

2.16.3 Other requirements for oil tankers carrying cargo oils having a flash point not exceeding 60 °C

2.16.3.1 Electrical motors used in connection with cargo pump rooms

Electrical motors driving equipment located in cargo pump rooms are to be separated from the pump room by a gastight bulkhead or deck. Flexible couplings or other means of maintaining alignment are to be fitted in the shafts between the motors and the driven unit. In addition, gastight and efficiently lubricated stuffing boxes are to be fitted where shafts pass through gastight bulkheads or decks.

2.16.3.2 Lighting for dangerous spaces

Where the dangerous spaces (e. g. cargo pump room, enclosed spaces other than cofferdams adjoining and below the top and compartment for cargo of a cargo tank, enclosed or semi-enclosed spaces immediately above cargo pump rooms, hoses) are lit through permanently fitted glass lenses or ports fitted in the bulkhead or deck, these glass lenses are to be robust in construction and are to maintain integrity of the structure as well as the integrity of gastightness and oiltightness. The lighting fittings and wiring are to be located in the non-dangerous spaces. Due consideration is to be given to the ventilation and heat dispersing of the fittings so that the glass lenses may not be subject to excess temperature rise.

2.16.3.3 Non-safe type equipment may be fitted in the following spaces:

- a. In tweendeck spaces having access solely from the deck above, and of which the floor is separated from the cargo tanks by a cofferdam and the boundaries are oiltight and gastight with respect to the cofferdam and the tweendeck spaces.
- b. In spaces forward of the cargo tanks at the same level with, or at a lower level than, the tank deck, which have direct opening on to the upper deck, if self-closing air lock doors are provided for the opening on to the upper deck, and in addition, mechanical ventilation is provided for the space, and the air inlet is remote from any dangerous zone or space.

2.16.4 Oil tankers carrying cargo oils having a flashpoint exceeding 60°C and not heated or heated to the temperature more than 15 °C below its flashpoint.

2.16.4.1 For tankers carrying cargo oils having a flashpoint exceeding 60 °C (closed cup test), where the cargo oil temperature is more than 15: below its flashpoint, no hazardous areas exist. The requirements in 2.16.1 are not applicable to such kind of tankers. However, the requirements in 2.16.4.2 to 2.16.4.6 below are to be complied with in order to avoid the possible ignition source.

2.16.4.2 No cables are allowed to be laid in the cargo tanks except for those connecting essential equipment in cargo tanks and to run in thick-walled bulkheads and gas-tight conduits up to the main deck.

2.16.4.3 Every cable of intrinsically safe electric circuit is to be in compliance with the requirements in 2.16.1.7.

2.16.4.4 Only intrinsically safe remote monitoring circuit is allowed to be used in cargo tanks and cargo pipes.

2.16.4.5 Electric equipment in cargo pump room is the one which will ensure the absence of spark or arcs and whose surface does not rise to an unacceptable level, during normal operation or of certified safe type.

2.16.4.6 Portable electrical installations used in cargo tanks are to be of certified safe type.

2.16.5 Oil tankers carrying cargo oils having a flashpoint exceeding 60°C and heated above its flashpoint or heated to the temperature less than 15°C of its flashpoint

2.16.5.1 The oil tankers are to be in compliance with the requirements of the oil tankers carrying cargo oils having a flashpoint not exceeding 60°C.

2.17 ADDITIONAL REQUIREMENTS FOR SHIPS CARRYING VEHICLES WITH FUEL IN THEIR TANKS FOR THEIR OWN PROPULSION

2.17.1 General requirements

2.17.1.1 This Section applies to the electrical equipment of ships with spaces for carrying vehicles with fuel in their tanks for their own propulsion.

2.17.1.2 Where electrical equipment is fitted within dangerous spaces, it is to be of certified safe type. The safe type electrical equipment is to comply with the requirements of 1.3.3 and 2.16.2.2.

2.17.2 in passenger ships with special category spaces above the bulkhead deck and closed ro-ro cargo spaces Of cargo ship's (to give less than 10 air changes per hour) for carrying vehicles.

2.17.2.1 Where electrical equipment is fitted within a height of 450 mm above the vehicles deck or platform and the exhaust ventilation trunking of the special category space, it is to be of certified safe type.

2.17.2.2 In spaces other than those required in 2.17.2.1, where electrical equipment other than the one of certified safe type is fitted, the enclosure of which is to be of at least IP55 type, and the temperature rise on the surface is not to exceed 200 °C.

2.17.3 in passenger ships with special category spaces below the bulkhead deck and closed ro-ro cargo spaces Of cargo ships (to give less than 10 air changes per hour) for carrying vehicles

2.17.3.1 Where electrical equipment is fitted within such spaces and its exhaust ventilation trunking, it is to be of certified safe type.

2.17.4 in passenger ship with ro-ro cargo spaces and cargo spaces other than special category spaces for carrying vehicles

2.17.4.1 Where electrical equipment is fitted within such spaces and its exhaust ventilation trunking, it is to be of certified safe type.

2.17.4.2 All electrical circuits of electrical equipment terminating in the cargo spaces are to be provided with multi-pole finked isolating switches located outside such spaces. Provision is to be made for locking in the off position. This does not apply to circuits such as fire, smoke or gas detectors.

2.17.5 in cargo spaces of cargo ships for carrying vehicles

2.17.5.1 Electric equipment fitted within 450 mm in height above the vehicle deck or in exhaust ventilation trunking of the cargo space are all to be of certified safe type.

2.17.5.2 In spaces other than required in 2.17.5.1, where electrical equipment other than the one of certified safe type is fitted, the enclosure of which is to be of at least JP55 type, and the temperature rise on the surface is not to exceed 200°C.

2.17.5.3 The provisions of 2.17.4.2 are to be applied to terminating circuit of the cargo spaces.

2.17.6 In passenger ships and weather deck spaces carrying vehicles

2.17.6.1 For the electrical equipment installed in the spaces, besides complying with the relevant requirements of Table 1.3.2.2, the temperature rise on the surface is not to exceed 200 °C.

2.18 ADDITIONAL REQUIREMENTS FOR SHIPS CARRYING DANGEROUS GOODS

2.18.1 General requirements

2.18.1.1 The electrical equipment onboard ships for carrying dangerous goods required in 2.18.1.2 in their dangerous cargo spaces are to comply with the requirements of this Section and other application requirements of this PART.

2.18.1.2 Dangerous goods, for which safety measures may be required with respect to the electrical equipment, are based on IMO International Maritime Dangerous Goods Code and Code of Safe Practice for Solid Bulk Cargos are grouped into the following classes:

- a. Dangerous goods in packaged form
 - Class 1 Explosive, except goods of division 1.4, compatibility group S;
 - Class 2.1 all flammable gases, compressed, liquefied or dissolved under pressure;
 - Class 3.1 all flammable liquids having a flashpoint below 23 °C (closed cup test);
3.2
 - Class 6.1 all poisonous substances having a flashpoint below 23 T (closed cup test);
 - Class 8 all corrosive liquids having a flashpoint below 23 °C (closed cup test).

- b. Solid dangerous goods in bulk
 - Class 4.1 Flammable solids;
 - Class 4.2 Substances liable to spontaneous combustion;
 - Class 4.3 Substances, which in contact with water, emit flammable gases;
 - Class 5.1 Oxidizing substances;
 - Class 9 Miscellaneous dangerous substances that is any other substance in respect of which experience has shown, or may show, to be of such a dangerous character that the provisions are apply to it.

MHB: The materials, when carried in bulk present sufficient hazards to require specific precautions.

2.18.1.3 Dangerous areas onboard ships for carrying the dangerous goods required in 2. 18. **1.2** comprises the following:

- a. Areas in which a dangerous gas/air mixture, dangerous vapours or concentration of dust and a dangerous quantity are liable to occur from time to time are defined to be the areas subject to explosion hazard (zone 1).
- b. Areas in which a dangerous gas/air mixture, dangerous vapours or concentration of dust and a dangerous quantity are liable to occur only seldom, and then for a brief period, are defined to be extended dangerous areas (zone 2) .

2.18.1.4 Electrical equipment are to be installed in hazardous areas only when it is essential for operational purposes. The explosion protection of the installed and operated electrical equipment is to be compatible with the characteristics of the dangerous cargo.

2.18.2 Carriage of explosive substances in packaged form, conforming to class 1, required in 2.18.1.2(1)

2.18.2.1 The following spaces or zones are the hazardous areas (zone 1):

- a. Enclosed or semi-enclosed cargo spaces, and enclosed or open m-m cargo spaces;
- b. Ventilation ducts for hazardous areas;
- c. Permanently fixed containers (boxes).

2.18.2.2 Cables required in 2.18.6.2 and the electrical equipment not less than the requirements of Table 2.18.2.2 are to be permitted to fit in the hazardous areas required in 2.18.2.1.

Table 2.18.2.2
Permitted electrical equipment

Environment	Electrical equipment			
	Type	Explosion group	Temp. Class or maximum surface temp.	Degree of protection
Explosive dust	General electrical equipment		100 °C	IP65
Explosive gas	Intrinsically safe Ex “i”	IIA	T5	
	Flameproof enclosure Ex “d”	IIA		
	Encapsulation Ex “m”	II		
	Increases safety type Ex “e” (only for Lighting	II		
Explosive and dust gas	Intrinsically safe Ex “i”	IIA	T5	IP65
	Flameproof enclosure Ex “d”	IIA		
	Encapsulation Ex “m”	II		
	Increased safety type Ex “e” (only for lighting	II		

2.18.3 Carriage of solid dangerous goods in bulk which may develop dangerous dust only

2.18.3.1 The following spaces or zones are hazardous areas (zone 1):

- a. Enclosed or semi-enclosed cargo holds;
- b. Ventilation ducts for hazardous areas;
- c. Enclosed or semi-enclosed spaces with non-closable (e.g. by doors or flaps) direct openings to (a) and (b).

2.18.3.2 Cables required in 2.18.6.2 and the electrical equipment not less than the following requirements are permitted to fit in the hazardous areas required in 2.18.3.1.

- a. General electrical equipment
 - Degree of protection IP55;
 - Maximum surface temperature 200 °C; or
- b. explosion-protected equipment
 - Degree of protection IP55;
 - Temperature class T3.

2.18.3.3 Where the characteristics of the cargo demand a lower surface temperature required in 2.18.3.2, the relevant requirements are to be complied with (see also 2.18.5)

2.18.4 Carriage of flammable liquids with a point below 23°C in packaged form, flammable gases and highly dangerous bulk cargoes which, under certain conditions, develop a potentially explosive gaseous Atmosphere

2.18.4.1 The following spaces or zones are hazardous areas:

- a. Hazardous areas (zone 1):
 1. Enclosed or semi-enclosed cargo holds;
 2. Ventilation ducts for hazardous areas;
 3. Enclosed or semi-enclosed spaces with non-closable (e. g. by doors or flaps) direct openings to (a) and (b);
- b. Hazardous areas (zone 2):
 1. Areas which can be separated by self-closed gastight doors (watertight doors can be regarded as the gastight) from the hazardous areas (zone 1), and have not overpressure ventilation (see 2.18.4.2);
 2. Bilge pump rooms and pipe ducts with components such as flanges, valves, pumps served for the hazardous areas (zone 1) (see 2.18.4.3);
 3. Areas on the weather deck or semi-enclosed rooms on the weather deck with openings within a spherical radius of 3 m about the exhaust openings of ventilation ducts from hazardous areas.

2.18.4.2 The areas required in 2.18.4.1 (b) a may be considered to be safe where they meet the following requirements:

- a. Have overpressure ventilation and at least 6 changes of air per hour. Where the ventilation fail, audible and visual alarms will be given and the electrical equipment not applying to hazardous areas (zone 2) will be switched off (see 2.18.4.5); or
- b. Are naturally ventilated and separated by self-closed air-locks from hazardous areas (zone 1) .

2.18.4.3 The areas required in 2.18.4.1 (2)^B maybe considered to be safe where they are ventilated with at least 6 changes of air per hour (exhaust air). Where the ventilation fail, audible and visual alarms will be given and the electrical equipment not applying to hazardous areas (zone 2) will be switched off (see 2.18.4.5).

2.18.4.4 In ventilated compartments, equipment important for the safety of the crew or the ship is to be so designed that it complies with the requirements for unventilated spaces. It is not to be switched off.

2.18.4.5 Unless otherwise stated in 2.18.4.6, the electrical equipment not less than the requirements of Table 2.18.4.5 and cables required in 2.18.6.2 is to be permitted to be in the hazardous areas required in 2.18.4.1.

Table 2.18.4.5
Permitted electrical equipment

Type of hazardous areas	Electrical equipment			
	Type	Explosion group	Temp. Class or maximum surface temp.	Degree protection
Zone 1	Intrinsically safe “i”	IIC	T4	IP55
	Flameproof enclosure Ex “d”	IIC		
	Pressurized type Ex “m”	II		
	Encapsulation Ex “m”	II		
	Special protection Ex “s”	II		
Zone 2	Permitted electrical equipment in zone 1	IIC or II	T4	IP55
	Equipment of protection class Ex “n”	II		
	Appliances which do not generate spark under normal work		135 °C	
	Appliances with simplified pressurized enclosures or vapour proof enclosures (minimum class of protection IP55)			

2.18.4.6 If capes to be carried have no hydrogen or hydrogen mixtures, or in bulk which may produce hydrogen under certain conditions, the explosion group required in 2.18.4.5 may be set to IIB.

2.18.5 Special requirements

2.18.5.1 If no details of the characteristics of the prospected cargo are available, or if a ship is intended to be used for the carriage of all the materials required in 2.18.1.2, the electrical equipment are to be in compliance with the following requirements:

- a. Degree of protection IP65;
- b. Maximum surface temperature 100°C;
- c. Explosion group IIC;
- d. Temperature class T5.

2.18.5.2 on ships intended exclusively for the carriage of containers, where containers with dangerous goods required in 2.18.1.2 are stowed in the cargo holds with the exception of class 1 goods, hydrogen and hydrogen mixtures, the electrical equipment am to be in compliance with the following requirements:

- a. Degree of protection IP55;
- b. Maximum surface temperature 135 °C;
- c. Explosion group IIB;
- d. Temperature class T4.

2.18.6 Installation of electrical system in hazardous areas

2.18.6.1 If electrical equipment are installed which are not suitable for use in areas with an explosion hazard, they are to be capable of being switched-off and safe-guarded against unauthorized m-switching (see also 2. 18.4.4). The switching devices are to be located outside the hazardous area, and arc to, where possible; include isolating links or lockable switches.

2.18.6.2 Cables are to be armoured or laid in metallic conduits.

2.18.6.3 Cables joints in cargo spaces are to be avoided where possible. When joints are unavoidable, they are to be enclosed in explosion-protection metallic or high strength plastic junction boxes, or encapsulated crimp sleeve cable joint.

2.18.6.4 In hazardous areas (zone 1), bulkhead and deck penetration arc to be sealed to prevent the passage of gases or vapours.

2.18.7 Portable electrical equipment in hazardous areas

2.18.7.1 Portable electrical equipment which are necessary for ship operation am to be safe type certified for the Zones where they are expected to be used.

2.18.8 Miscellaneous

2.18.8.1 Where the fire main pressure drops, the fire pumps are to start automatically or are to be switched on by a remote-starting device installed on the bridge (see also PART SIX) .

2.18.8.2 In the certificate issued by the Society for carrying dangerous goods an entry is to be made specifying the kind of explosion protection installed.

2.18.8.3 The characteristics of electrical equipment for use in hazardous areas for carriage of solid bulk cargoes are shown in Table 2.18.8.3.

Table 2.18.8.3

Characteristics of electrical equipment for use in hazardous areas for the carriage of solid bulk cargoes

Dangerous goods	IMO class	Hazard ^A	Protection against		
			Explosive dusts		Explosive atmosphere
			Degree of protection	Explosion group	Temp. class
Aluminium dross	MHB	H ₂	–	IIC	T2
Aluminium ferrosilicon powder	4.3	H ₂	–	IIC	T2
Aluminium silicon powder uncoated	4.3	H ₂	–	IIC	T2
Coal	MHB	Dust, methane	IP55	IIA	T4 ^B
Directly reduced iron	MHB	H ₂	–	IIC	T2
Ferrophosphorus (excl. briquettes)	MHB	H ₂	–	IIC	T1
Ferrosilicon	4.3	H ₂	–	IIC	T1
Iron oxide, spent	4.2	Dust	IP55	IIA	T2
Sponge iron, spent	4.2	Dust	IP55	IIA	T2
Dust (e.g. from grain)	4.2	Dust	IP55	–	–
Squeezed aromatic plant seeds	4.2	Hexane	–	IIA	T3
Silicon manganese	MHB	H ₂	–	IIC	T1
Sulphur	4.1	Combustible material	IP55	–	T4
Zinc ashes	4.3	H ₂	–	IIC	T2
Zinc dross	4.3	H ₂	–	IIC	T2
Zinc residues	4.3	H ₂	–	IIC	T2
Zinc skimmings	4.3	H ₂	–	IIC	T2

Note:

- A. The term "hazard" relates exclusively to the danger of explosion attributable to the dangerous goods and the electrical appliances.
- B. The maximum surface temperature may be 180 °C.

CHAPTER 3: SPARE PARTS

3.1 GENERAL REQUIREMENTS

3.1.1 General requirements

3.1.1.1 Spare parts for electrical installations on each ship are generally not to be less than those as specified in this Chapter.

3.1.1.2 All spare parts are to be suitably packed and properly stored.

3.2 PROVISION OF SPARE PARTS

3.2.1 Electrical machinery

3.2.1.1 A.C. and D. C. Machine and exciters are to be provided with the following spare parts:

- a. Carbon brushes: 1 set;
- b. Brush holders, complete assembly: 1/4 set;
- c. Bearings: 1 for each type, 1 for each size.

3.2.1.2 The spare parts for steering gear with a duplicate set of motors are to be provided in accordance with the requirements of 3.2.1.1. If the steering gear is fitted with only one set of motor, the spare parts are, in addition to those required in 3.2.1.1, to include the following:

- a. One unit of armature with shaft and half-coupling and one set of field winding of each type for D.C. actuating motor and one complete electrical motor for A.C. actuating motor.

3.2.1.3 The air cooler fans in refrigerated cargo ships are to be provided with spare parts in accordance with 3.2.1.1, and in addition, if no spare motor is available, the following parts are to be provided:

- a. One unit of armature and one set of field winding for each 6 identical D.C. motors (if the number of motors is less than 6, it is to be taken as 6);
- b. One complete stators for each 6 identical A. C. motors (if the number of motors is less than 6, it is to be taken as 6)

3.2.2 Provision of electric appliances

3.2.2.1 The distribution equipment is to be provided with the following spare parts:

- a. Circuit breakers:

contacts liable to wear down: 1 set,
springs (including springs of auxiliary contacts): 1 set,
tripping coils : 1 piece of each type and size,
arcing chambers: 1 piece;

- b. Fuses: 15% of each type and size, but at least 6;
- c. Resistance elements: 1 piece of each type and size;
- d. Change-over switches for meters: 1 piece of each type and size;
- e. Switches: 2 pieces of each type and size;
- f. Indicating lamps: 1 set.

3.2.2.2 Control gear is to be provided with the following spare parts:

- a. Contractors and controllers
contacts liable to wear down: 1 set,
springs (including springs of auxiliary contacts): 1 set,
attracting coils of contractors: 1 coil;
- b. Resistance elements: 10% of each type and size, but at least 1;
- c. Indicating lamps: 1 set.

3.2.2.3 The navigation lamps and signal lamps are to be provided with the following spare parts:

lamp bulbs: 2 sets;
lenses or glasses: 1 set of each type.

3.2.2.4 Daylight signaling lamps are to be provided with two spare bulbs.

3.2.2.5 If the voltage of emergency lighting system differs from that of main lighting system, the emergency lighting is to be provided with one set of spare bulbs.

CHAPTER 4 CONSTRUCTION AND TESTING OF ELECTRICAL EQUIPMENT

4.1 ROTATING MACHINES

4.1.1 General requirements

4.1.1.1 The characteristics of the prime movers of generators and their governors are to comply with the relevant requirements of these regulations.

4.1.1.2 When generators are operated in parallel, the governing characteristics of the prime mover are to ensure the load sharing specified in 4.1.6.5 and 4.1.7.6. Adjusting facilities sufficiently fine are to be provided to permit an adjustment of load on the engine, at normal frequency, within 5 % of full load.

4.1.1.3 Materials used for the shaft of the rotating machines for essential services are to comply with the requirements of the Rules for Materials and Welding by the Society.

4.1.1.4 Means are to be taken to prevent the electrical machines from being impaired by the ill effects of shaft current.

4.1. 1. 5 All bearing housings of electrical machines are to be provided with grease cups or greasing holes and corresponding overflow passages so as to ensure efficient lubrication.

4.1.2 Temperature rise

4.1.2.1 The limits of temperature rise of air-cooled machines based on an ambient air temperature of 45 °C are as given in Table 4.1.2.1.

Table 4.1.2.1
Limits of temperature rise (K) of air-cooled machines

Thermal Classification		A			E			B						H		
Metod of measeurement		Th	R	ETD	Th	R	ETD	Th	R	ETD	Th	R	ETD	Th	R	ETD
Item	Part of machine															
1 a)	AC windings of machines having outputs of 5000kW (or KVA) or more	-	55	60	-	-	-	-	75	80	-	95	100	-	120	125
1 b)	AC windings of machines having outputs of 5000kW (or KVA) or more	-	55	60	-	70	-	-	75	85	-	100	105	-	120	125
1 c)	AC windings of machines having outputs of 5000kW (or KVA) or more	-	55	-	-	70	-	-	75	-	-	100	-	-	120	-



Thermal Classification		A			E			B			H					
Method of measurement		Th	R	ETD	Th	R	ETD	Th	R	ETD	Th	R	ETD			
Item	Part of machine															
1 d)	AC windings of machines having outputs of 5000kW (or KVA) or more	-	60	-	-	70	-	-	80	-	-	105	-	-	125	-
1 e)	AC windings which are selfcooled without a fan (IC410) and/or with encapsulated winding		60	-	-	70	-	-	80	-	-	105	-	-	125	-
2	Windings of armatures having commutators	45	55	-	60	70	-	65	75	-	80	100	-	100	120	-
3	Field windings of a.c. and d.c. machines other than those in item 4	45	55	-	60	70	-	65	75	-	80	100	-	100	120	-
4a)	Field windings of synchronous machines with cylindrical rotors having a d.c. excitation winding embedded in slots, except synchronous induction motors	-	-	-	-	-	-	-	85	-	-	105	-	-	130	-



Thermal Classification		A			E			B			H					
Method of measurement		Th	R	ETD	Th	R	ETD	Th	R	ETD	Th	R	ETD			
Item	Part of machine															
4b)	Insulated stationary field windings of d.c. machines having more than one layer	45	55	-	60	70	-	65	75	85	80	100	105	100	120	130
4c)	Low- resistance field windings of a.c. and d.c. machines having more than one layer and compensating windings of d.c. machines	55	55	-	70	70	-	75	75	-	95	95	-	120	120	-
4d)	Single-layer windings of a.c. and d.c. machines with exposed bare or varnished metal surfaces	60	60	-	75	75	-	85	85	-	105	105	-	130	130	-
5	Permanently short-circuited windings	The temperature rise or the temperature is not to be detrimental to the insulation of that part or to any other part adjacent to it														
6	Commutators and sliprings and their brushes and brushgear	The temperature rise or temperature of any commutator, slipring, brush or brushgear is not to be detrimental to the insulation of that part or any adjacent part, In addition, the temperature rise or temperature of a commutator or slipring does not exceed that at which the combination of brush grade and commutator or slipring material can handle the current over the full operating range														
7	Structural components and magnetic cores whether or not contact with insulation (other than bearings)	The temperature rise or the temperature is not to be detrimental to the insulation of that part or to any other part adjacent to it														

Note: ① With application of the superposition test method to windings of machines rated 200 kW (or kVA) or less with insulation classes A, E, B and F, the limits of temperature rise given for the resistance method may be exceeded by 5K.

② Also includes multiple layer windings provided that the under layers are each in contact with the circulating primary coolant.

③ In the table, Th-thermometer, R-resistance, and ETO-embedded temperature detector.

4.1.2.2 Where the ambient temperature of motor operation is more than 45°C, the permissible temperature rise is to be reduced by an amount equal to difference between actual ambient temperature and 45 °C, base on the specified value given in Table 4.1.2.1.

Where the ambient temperature of motor operation is less than 45 °C) the permissible temperature rise is to be increased by an amount equal to difference between actual ambient temperature and 45 °C, base on the specified value given in Table 4.1.2.1 and the increased value is not to be more than 15K.

4.1.2.3 Main and emergency generators, including their exciters, and continuous duty motors are to be suitable for continuous duty at their full rated output at maximum cooling air or cooling water temperature for an unlimited period, without the limits of temperature rise in Table 4.1.2.1 being exceeded. Other generators and motors are to be rated in accordance with the duty of which they are to perform, and when tested under rated load conditions the temperature rise is not to exceed the values given in Table 4.1.2.1.

4.1.3 Sparking

4.1.3.1 Direct current motors and generators are to work with fixed brush setting from no load to the momentary overload specified without injurious sparking.

4.1.3.2 Alternating current commutator motors are to work over the specified range of load and speed without injurious sparking.

4.1.4 Overloads

4.1.4.1 Machines are to withstand, on test, the following overcurrent or excess torque without injury:

D.C. generators: 50% overcurrent 15 s;

A.C. generators: 50% overcurrent 2 min;

D.C. motors: 50% excess torque 15 s.

Polyphase asynchronous motors: 60% excess torque 15 s.

Polyphase salient synchronous motors: 50% excess torque 15 s.

Polyphase non-salient synchronous motors: 35% excess torque 15 s.

Polyphase asynchronous construction synchronous motors (winding rotator): 35% excess torque 15 s.

4.1.5 Short-circuits

4.1.5.1 Ships service generators are to be capable of withstanding the mechanical and thermal effects of fault current for the duration of any time delay which may be fitted in a tripping device for discrimination

purposes. For A.C. generators and their excitation systems, they are to be capable of maintaining, under steady-state short-circuit conditions, a current of at least 3 times the full load rated current *for a duration of at least 2 s*, or where precise data is available, for the duration of any time delay which may be fitted in a tripping device for discrimination purposes.

4.1.6 D.C. generators

4.1.6.1 All D.C. generators other than the charging generators are, in general, to be of compound wound type or shunt wound type with automatic voltage regulator, or stabilized shunt wound type (shunt type with few turns of series windings).

4.1.6.2 Manual voltage regulators are to be provided at the control panel to enable the voltage of each D.C. generator to be adjusted separately. For each D.C. generator, at any temperature within the working range and at any load between no load and full load, and when the voltage varies from 80% to 105% of the rated value, the accuracy of voltage adjustment is to be as follows:

- a. 0.5% of rated voltage for generators of rating exceeding 100 kW;
- b. 1.0% of rated voltage for generators of rating not exceeding 100 kW.

The circuit of manual voltage regulators is in general to be capable of being opened and means are to be provided to protect against over-voltage when the circuit is open. Non-opened circuit is permitted only in such a case when the manual voltage regulator could adjust the no-load voltage to a value approaching to the residual magnetism voltage. The handwheel of manual voltage regulators is to be so arranged that when it is rotated in clockwise direction, the generator voltage is to rise and vice versa.

4.1.6.3 Equalizer connections are to have a cross-sectional area appropriate to the system but in no case less than 50% of that of the negative connection from the generator to the switchboard.

4.1.6.4 For compound wound generators at full load operating temperature, and with due regard being paid to the speed characteristics of the prime mover, the voltage regulating characteristics of the generator are to be as follows: When starting at 20% load with voltage within 1% of rated voltage, then at full load the voltage is to be within 2.5% of rated voltage. The average of the ascending and descending load/voltage curves between 20% load and full load is not to vary more than 4% from rated voltage.

4.1.6.5 All D.C. generators arranged to run in parallel are to be stable in operation. When the combined load on the sets is varied between 20% and 100% of the combined ratings, the individual load on each machine is not to differ from the theoretical load (proportional to rating) by an amount greater than:

- a. $\pm 12\%$ of the rated full load of the largest machine ; or
- b. $\pm 25\%$ of the rating of the smallest machine when the rating of the smallest machine is less than 50% of that of the largest one. Such a load sharing is not to result in overloading the smaller set.

4.1.6.6 D. C. generators driven by main engines at varying speeds during the operation of the ship are to be provided with control facilities, and are to comply with the following requirements:

- a. The variation of the terminal voltage is to be maintained practically constant so as to ensure normal operation of the power consuming equipment when the shaft speed varies within the specified ranges;
- b. The equipment is to be capable of delivering its rated output at least within the range of 75 % to 100% of the rated speed of the main engine;
- c. The equipment is to have a certain overload capacity.

4.1.7 A.C. generating sets

4.1.7.1 Each A.C. generator, unless of the self-regulated type, is to be provided with separate automatic and manual voltage regulators at the generator control panel.

4.1.7.2 Each A.C. generator driven by the prime-mover having governor characteristics complying with these regulations together with its excitation system is to be capable of maintaining the voltage under steady conditions within ± 2.5 % of the rated voltage for all loads between zero and rated load at rated power factor. These limits may be increased to ± 3.5 % for emergency sets.

4.1.7.3 For A.C. generating sets under no load conditions, when the prime mover has been adjusted to run at rated speed and with the voltage of the generator approaching to its rated value, a balance load equal to 60% of the full load current at any power factor not exceeding 0.4 lagging is suddenly applied and suddenly removed, the transient voltage of the generator is not to be less than 85 % of the rated voltage when the voltage is dropping, and not to exceed 120% of the rated voltage when the voltage is rising. And the time required for the voltage to restore to within 3% from the final steady voltage is not to exceed 1.5 s.

4.1.7.4 For A.C. synchronous generators, the factor of distortion of the waveform from a sinusoidal fundamental of the line-to-line voltage under no load conditions is not to exceed 5%, except for small size (e.g. less than 24 kW) generators.

4.1.7.5 A.C. generators driven by main engines at varying speeds during the operation of the ship are to be provided with control facilities, and are to comply with the following requirements:

- a. The variation of the terminal voltage and frequency is to be maintained practically constant so as to ensure normal operation of the power consuming equipment when the shaft speed varies within the specified ranges;
- b. The equipment is to be capable of delivering the rated output at least within the range of 75 - 100% of the rated speed of the main engine;
- c. The factor of distortion of the waveform from a sinusoidal fundamental of line-to-line voltage may exceed 5% , if measures are taken to ensure that this does not interfere with the operation of the consumers or other equipment such as radio and navigation facilities;
- d. The equipment is to have a certain overload capacity.

4.1.7.6 All A.C. generating sets arranged to run in parallel are to be stable in operation. When the combined load on the sets is varied between 20% and 100% of the combined rating, the variations of load sharing are to be as follows:

- a. The individual active load on each generator is not to differ from the proportionate share of the total load by an amount greater than the smaller of the following:
 - ± 15% of the rated active output of the largest generator;
 - ± 25% of the rated active output of the individual machine in question.
- b. The reactive loads of the individual generating sets are not to differ from the proportionate share of the total reactive load by an amount greater than the smaller of the following:
 - ±10% of the rated reactive output of the largest generator;
 - ±25% of the rated reactive output of the smallest generator.

4.1.8 Testing

4.1.8.1 All electrical machines for essential services are to be subjected to all kinds of function tests as required in 4.1.8.3, and to have test certificate issued by the manufacturer is to be secured.

4.1.8.2 Motors of 100kW and over intended for essential services, are to be surveyed by the Surveyor during testing and, if appropriate, during manufacturing. Where a quality assurance system of the manufacturer has been approved by the Society, attendance of the Surveyor is not necessary.

4.1.8.3 Items for type and routine tests of the electrical machines are to be in compliance with the provisions in Table 4.1.8.3

Table 4.1.8.3
Items For Type and Routine Test of Electric Machines (E 13/Table 1)

No	Test	A.C. Generators		Motors	
		Type test	Routine test	Type test	Routine test
1	Examination of the technical documentation as appropriate and visual inspection	x	x	x	x
2	Insulation resistance measurement	x	x	x	x
3	Winding resistance measurement	x	x	x	x
4	Verification of the voltage regulation system	x	x ⁽¹⁾	x	x
5	Rated load test and temperature rise measurements	x	x	x	x
6	Overload/over current test	x	x ⁽²⁾	x	x ⁽²⁾
7	Verification of steady short circuit conditions ⁽³⁾	x	x	x	x
8	Overspeed test	x	x	x ⁽³⁾	x ⁽³⁾
9	Dielectric strength test	x	x	x	x
10	No-load test	x	x	x	x
11	Verification of degree of protection	x	x	x	x
12	Verification of bearings	x	x	x	x

Notes:

- ① Only functional test of voltage regulator system;
- ② Only applicable for machine of essential services rated above /00kW/kVA,.
- ③ Verification of steady short circuit condition applies to synchronous generators only;
- ④ Not applicable for squirrel cage motors. "

4.1.8.4 The tests required in Table 4.1.8.3 are to be in accordance with the requirements in 4.1.8.5 to 4.1.8.9, in addition to complying with the relevant requirements of the standards accepted by the Society.

4.1.8.5 Insulation resistance measurement

Immediately after the high voltage tests the insulation resistances are to be measured using a direct current insulation tester. The minimum values of test voltages and corresponding insulation resistances are given in Table 4.1.8.5. The insulation resistance is to be measured close to the operating temperature, or an appropriate method of calculation is to be used.

Table 4.1.8.5
Minimum values of test voltages and insulation resistances

Related Voltage U_n (V)	Minimum Test Voltage (V)	Minimum Insulation Resistance (M)
$U_n < 250$	$2 \times U_n$	1
$250 < U_n < 1000$	500	1
$1000 < U_n < 7200$	1000	$(U_n / 1000) + 1$
$7200 < U_n < 15000$	5000	$(U_n / 1000) + 1$

4.1.8.6 Verification of voltage regulation system

Verification results are to meet the requirements in 4.1.7.2 and 4.1.7.3.

4.1.8.7 Rated load test and temperature rise measurements

Electrical machines are to be subject to rated load test as required in IEC Publication 60034-1 or other combination test method under rated output, rated voltage, rated frequency and rated duty. Temperature rise is to be measured after the test, the limit value of the temperature rise is not to exceed that required in Table 4.1.2.1.

4.1.8.8 Overload/over-current tests Electrical machines are to be able to withstand the overload/over-current tests as required in 4.1.4.1 after the rated load test. The overload test can be replaced at routine test by the overcurrent test.

4.1.8.9 Verification of steady short-circuit condition

Verification of synchronous generator and its excitation system is to be in accordance with the requirements in 4.1.5.1.

4.1.8.10 Dielectric strength test

Machines are to withstand a dielectric test as specified in standard(s) acceptable to the Society For high voltage machine an impulse test is to be carried out on the coils according to 2.14.3.3.

4.1.8.11 Verification of degree of protection

As specified in standard(s) acceptable to the Society.

4.1.8.12 After the special testing is finished, the sleeve bearing is to be dismantled for inspection where necessary.

4.2 SWITCHGEAR ASSEMBLIES

4.2.1 Design and construction of switchgear assemblies

4.2.1.1 The construction of main and emergency switchboards is to satisfy the following requirements:

- a. The top of switchboards is to have a degree of protection of IP22, and where the switchboard is installed in the control room complying with the requirements of 2.1.4.2 of this PART, a protection of IP21 at the top may be accepted. The sides of switchboards are to have a degree of protection of IP2X. For switchboards having a rated voltage in excess of 500 V a protection of at least IP2X at the rear is to be provided.
- b. For voltages to earth or a working voltage above 50 V, exposed live parts are not installed on the front of such switchboard.
- c. Insulated hand rails of rigid construction are to be provided at the front and rear of all main and emergency switchboards. Where the mar is open, a horizontal insulated handrail is to be fitted on the mar of the switchboard.
- d. Provision is to be made at the cable entry to switchboards so that there is no water leakage into the switchboard along the cables.
- e. Main bus-bar is to be subdivided in accordance with the requirements in 2.1.1.1(e).
- f. Where the total capacity of the main generating sets exceed 3 MW, separate generator panel is to be provided for each generator, and the panels are to be separated from each other by partitions of steel or flame-retardant material.
- g. Terminals for systems having a rated voltage above 500 V are to be separated from terminals for lower voltage and are to be clearly marked.

4.2.1.2 Section and distribution boards are to be suitably enclosed unless they are installed in a cupboard or compartment to which only authorized persons have access.

All enclosures are to be constructed of non-flammable and non-hygroscopic material, and are to be of robust construction.

4.2.1.3 The arrangement of protection of electrical installations and the choice of protective devices are to comply with the relevant requirements of 2.5.

4.2.1.4 All instruments, switchgear, pilot lamps, push buttons, operating handles or handwheels, etc., fitted on switchboards are to be provided with durable labels bearing their purposes and operating positions.

4.2.1.5 A durable label indicating the purposes and the rating or appropriate setting of the overload protective device of each circuit is to be provided at the location of the protective device. For fuses above 500 V, when the fuse holders permit the insertion of fuses for lower rated voltage, special warning labels are to be placed, for example, 660 V FUSES ONLY !.

4.2.1.6 Devices for monitoring the insulation level to earth, which are in compliance with the requirements of 2.4.2.2, are to be provided in the main and emergency switchboards.

4.2.1.7 Pilot lamps are to be provided at the generator control panels to indicate whether the generator circuit breakers are at the on or off position.

4.2.1.8 Means are to be provided at the control panels of the D.C. generators to enable the voltage to be adjusted in accordance with the requirements of 4.1.6.2.

4.2.1.9 For each A.C. generator arranged to operate in parallel, a remote control device is to be provided at the control panel to enable the speed of the prime mover to be adjusted to within 10% of its rated value.

4.2.1.10 Means are to be provided at the control panel for the flash-magnetization of the field of D.C. generators.

4.2.1.11 The circuit breakers of main generators are to be interlocked with the shore connection so as to prevent the simultaneous supply.

4.2.1.12 Shore connection boxes of shore supply or other external sources are to be provided with the following:

- a. Suitable terminals for connecting the flexible cables;
- b. An earth terminal for connecting the hull to the shore earth;
- c. Switches with necessary protection complying with the requirements of 2.5.9.5;
- d. A lamp or voltmeter to indicate the terminal voltage;
- e. Means for checking the polarity (for direct current) or the phase sequence (for three-phase A. C .) of the incoming supply in relation to the ships system;
- f. Means to prevent the connecting ends sustaining mechanical forces;
- g. A nameplate giving full information on the system of supply, the rated voltage and frequency (for A.C.).

4.2.2 Bus-bars

4.2.2.1 Bus-bars are to be made of conducting cathode copper or copper-sheeted aluminium alloy. The maximum permissible temperature rise for bus-bars is 45 K.

4.2.2.2 Bus-bars and their supports are to be designed to withstand the mechanical stresses which will arise during Short-circuits.

4.2.2.3 Bare main busbars in main and emergency switchboards (but excluding the conductors between the main busbars and the supply side of out-going units) , are to have the minimum clearances and creepage distances as given in Table 4.2.2.3.

Table 4.2.2.3
Minimum clearances (mm)

Voltage between phases or poles (V)	Minimum clearances (mm)	Minimum creepage distances (mm)
Un < 250	15	20
250 < Un < 690	20	25
Un > 690	25	35

4.2.2.4 The current rating of equalizer bus-bars is not to be less than 50 % of the rated full load current of the largest generator in the generating plant.

4.2.2.5 The cross sectional area of neutral bus-bar in A.C. three phase-four wire system is not to be less than 50% of that of the corresponding phase (pole) bus-bar.

4.2.2.6 Bus-bars in the switchboards are to be arranged in accordance with Table 4.2.2.6 (as viewed from the front of the assembly).

Table 4.2.2.6
Arrangements of phases or poles

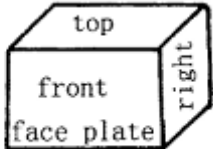
Busbars	Phases or Poles	Arrangements			Sketch
		vertically	horizontally	outgoing	
A.C.	1 st phase	top	front	left	As viewed from the front of switchboard assembly 
	2 nd phase	middle	middle	middle	
	3 rd phase	bottom	back	right	
D.C.	Positive pole	top	front	left	
	Equalizer pole	middle	middle	middle	
	Negative pole	bottom	back	right	

4.2.3 Measurhg instruments

4.2.3.1 The precision grade of instruments is to be selected according to the service of the instruments, but in no case is the precision grade to be inferior to 2.5.

- 4.2.3.2 The range and scale of the measuring instruments are to comply with the following requirements:
- The upper limit of the scale of every voltmeter is to be approximately 120% of the normal voltage of the circuit.
 - The upper limit of the scale of every ammeter is to be approximately 130% of the normal rating of the circuit in which it is installed.
 - Ammeters for use with direct current generators, and kW meters for use with alternating current generators which may be operated in parallel, are to be capable of indicating 15% reverse current or power respectively.
 - The frequency meter is to have a scale range of $\pm 10\%$ of the rated frequency.
 - Ammeters, voltmeters and wattmeters are to be clearly marked with a red line on the scale to indicate their rated values.

4.2.3.3 Generator control panels am to be provided with measuring instruments as required in Table 4.2.3.3.

Table 4.2.3.3
Measuring instruments of generator control panels

Generator	Operating condition	Type of instrument	Quantity
D.C.	Not in parallel	Ammeter	1 for each generator (connected to positive pole)
		Voltmeter	1 for each generator
	In parallel	Ammeter	1 for each generator (connected to positive pole)
		Voltmeter	2(1 for measuring the busbar voltage, 1 for measuring the voltage of each generator)
A.C.	Not in parallel	Ammeter	1 for each generator(to be culpable of measuring the current in each phase or each line separately)
		Voltmeter	1 for each generator(to be culpable of measuring the current in each phase or each line separately)
		Wattmeter	1 for each generator(may be omitted for generators rated lees than 50 kW (KVA)
		Frequency	1 for each generator meter
		Excitation ammeter	1 for each generator (to be fitted only when necessary
	In parallel	Ammeter	1 for each generator(to be culpable of measuring the current in each phase or each line separately)
		Voltmeter	2(1 for measuring the voltage in each phase or each line of the generator separately, 1 for measuring the busbar voltage)
		Wattmeter	1 for each generator
		Frequency meter	2(1 for measuring the busbar voltage, 1 for measuring the frequency of each generator)
		Synchroscope	1 for all generators
		Excitation ammeter	1 for each generator (to be fitted only when necessary)

4.2.3.4 The secondary windings of potential and current transformers are to be effectively earthed.

4.2.4 Circuit breakem and switches

4.2.4.1 Circuit breakers are to be of the trip-free type.

4.2.4.2 Each circuit opening device is to be so arranged that when placed in the OFF position it cannot accidentally move to close the circuit.

4.2.4.3 The protective performance of circuit breakers for generators is to comply with the requirements of 2.5.6. The overcurrent release of these circuit breakers are to be adjustable, or, if of the non-adjustable type, am to be readily replaceable by others of different values.

4.2.4.4 Where circuit breakers are operated by a power operating device, a hand operated mechanism is to be provided to operate the circuit breaker in case of failure of the electrical driven gear and is to be operated at the front of panels.

4.2.4.5 The fused circuit breakers am to be so constructed that single phasing does not occur in the event of blowing of fuses and that the fuses can be replaced easily without the risk of accidental touch to their live parts.

4.2.4.6 Durable labels am to be fitted on circuit breakers to indicate their rated voltage, rated current and the setting of the over-circuit trip device, etc.

4.2.5 Fuses

4.2.5.1 Fuses are to be of enclosed type and the construction is to be such that its enclosure is not broken or burnt and the adjacent insulation is not deteriorated by melted metal or emitted gases, when the fuse element has blown out.

4.2.5.2 Fuses are to be easily replaceable for their spare parts without the risk of getting electrical shock or bum on removing and replacing of fuses.

4.2.5.3 When fuses are operating for long periods under rated current, the temperature rise at the terminals is to be such that the maximum permissible temperature of the connected cable is not exceeded.

4.2.5.4 Fuses are to be marked to indicate their rated voltage, rated current and rated breaking capacity.

4.2.6 Testing

4.2.6.1 Switchboards are to be tested at the manufacturer's works in accordance with the provisions of 4.2.6.2 to 4.2.6.5 of this Section. However, the test required in 4.2.6.2 may be omitted for batch products of same type, subject to agreement of the Society.

4.2.6.2 Switchboards are to be subjected to temperature rise test under the specified load current.

4.2.6.3 Switchboards are to be tested under operating conditions for verifying the function of instruments and switchgear.

4.2.6.4 Switchboards are to be subject to high voltage test as required in Table 4.2.6.4.

Table 4.2.6.4
Test voltage

Rated voltage	Test voltage	Test requirements
< 60	500 V	The high voltage test is made with an A.C. voltage of 25 to 100Hz, and the switchboards are to withstand the test voltage for a duration of one minute without any break down or flash over
>60	1000 V + twice the rated voltage with a minimum of 2000 V	

Notes:

- ① During testing all semi-conductor component parts are to be disconnected from the circuits to be tested and in the meantime, the measuring instruments, condensers, pilot lamps and other ancillary apparatus may also be disconnected.
- ② The test voltage is to be applied between all current carrying parts and earthed frame, and between current carrying parts of opposite polarity or phase.

4.2.6.5 Immediately after the high-voltage test, the insulation resistance between all current-carrying parts connected together and earth, and between current-carrying parts of opposite polarity or phase, is not to be less than $1M\Omega$ when tested with a D.C. 500 V megameter.

4.3 CONTROL GEAR

4.3.1 General requirements

4.3.1.1 The control wheels or handles of the control gear are to comply with the following requirements:

- a. The temperature is not to exceed 55°C for metal parts and not to exceed 65°C for the insulated parts.
- b. They are to be provided with mechanically locking devices so that they will not change their operating positions due to shock or vibration.
- c. They are to be provided with durable labels to indicate their purposes, positions and effect of movement.

4.3.1.2 The handwheels of the control gear are to be arranged to rotate in a clockwise direction to produce the effects of: increase motor speed, lifting, heavy-up anchor, haul-in rope, and conversely : decrease motor speed, lowering, lower-down anchor, pay-out rope, etc. , if position "0" is a starting point;

The handles of control gear are to be arranged to move forward to produce the effects of: lower-down anchor, pay-out mpe7 lowering; and conversely, hand-in rope, heavy-up anchor, lifting, etc. , if position "0" is a starting point.

4.3.1.3 The control gear is to be provided with protective devices complying with the relevant requirements of 2.5.

4.3.1.4 Suitable means are to be provided for the control push buttons against wrong action due to inadvertent touching.

4.3.1.5 The shunt coils of electro-magnetic brakes or electro-magnetic couplings are to be provided with discharge circuits to protect against damage to windings due to induced over-voltage.

4.3.2 Motor control gear

4.3.2.1 The motor control gear is to be provided with indicating devices to show that the motor is running.

4.3.2.2 The motor control gear is also to comply with the relevant requirements of 2.6. The control gear of the steering gear is also to comply with the relevant requirements of these regulations.

4.3.2.3 The control gear of windlasses, warping winches, and cargo winches is to be provided with a device for emergency disconnection of the circuits.

4.3.2.4 Where windlass motors and warping winch motors have rating equal to or more than 10 kW, their controllers are to be provided with an ammeter to supervise the operating current of the motors, this ammeter is to be properly illuminated or to be of fluorescent type.

4.3.3 Testing

4.3.3.1 Temperature rise test

Control gear is to be subjected to temperature rise test under normal working conditions.

4.3.3.2 Operating test

All control gears are to be tested under operating conditions.

4.3.3.3 High voltage test

Control gear and resistors are to be tested by the makers with a high voltage applied between the earthed frame and all live parts.

The test voltage is to be:

- a. For rated voltage up to 60V: 500V
- b. For rated voltage above 60 V : 1000 V + twice the rated voltage with a minimum of 2000 V.

The voltage is to be alternating at any frequency between 25 and 100 Hz and is to be maintained for one minute without break down or flash over. Instruments and ancillary apparatus may be disconnected during the high voltage test.

4.3.3.4 Insulation resistance test

Immediately after the high voltage test, the insulation resistance is not to be less than 1 MSZ when tested with a direct current megameter of at least 500 V.

4.4 CABLES

4.4.1 General requirements

4.4.1.1 Cables are to comply with the requirements of this Section, those not covered in this Section are to comply with the relevant requirements of the standard accepted by the Society.

4.4.1.2 The thickness of insulation and sheath of cables is generally to comply with the relevant requirements in the standards accepted by the Society. Cables with other dimensions will be considered if they comply with an approved specification for marine cables.

4.4.1.3 The quality of materials of cables is to comply with the relevant requirements of standards@ accepted by the Society.

4.4.2 Conductors

4.4.2.1 Copper with metallic coating or without metallic and being annealed is to be used for conductors. Unless conductor and insulation is separated, the copper wire of thermoset insulated conductor is to be metallic coated and the surface is to be bright. The thermoplastic insulated conductor may not be metallic coated.

4.4.2.2 Conductor composition and stranding is to be so selected that adequate flexibility of the finished cable is assured. Cores of multi-core cables are to be readily identifiable.

4.4.3 Insulating materials

4.4.3.1 Permitted insulating materials with maximum rated conductor temperatures are to comply with the requirements of 2.12.2.2.

4.4.3.2 Cables with different maximum conductor temperatures are to be readily identifiable.



4.4.4 Insulation

4.4.4.1 For elastomeric or thermoplastic compound insulation, the use of a single layer of compounds is permitted only when applied by the extrusion process. With other processes the insulation is to consist of at least two layers of compounds equal in quality, and the layers are to be bonded together. The insulating wall is to be close fitting but not adherent to the conductor.

4.4.4.2 Mineral insulation is to consist of powdered mineral materials, e. g. magnesium oxide, highly compressed between conductors and copper sheath. It is to be temperature-stable and non-corrosive to copper.

4.4.5 Construction

4.4.5.1 Whatever the insulating material used, both the belted and non-belted construction may be used for two, three and more conductor cables.

4.4.5.2 For non-belted cables, the spaces among the cores are to be filled with fibrous or rubber-like fillers and the cylindrical assembly is to be sheathed with the appropriate protective covering. Fillers may be omitted in multi-core cables having conductor sections 4.5 mm or less. Alternatively, elastomeric or thermoplastic insulated cables may have a compatible compound extruded over the cabled cores so as to form, in one body, the fillers and a continuous covering similar to a sheath.

4.4.5.3 Belted cables are to be constructed as non-belted cables, except that an insulating wail is to be applied to the cabled cores before applying the protective covering. For elastomeric or thermoplastic insulated cables, the common belt is to be elastomeric or thermoplastic respectively, which may or may not form one body with the fillers.

4.4.5.4 When fibrous fillers are used they are to consist of jute or similar rovings (including asbestos, glass, etc.) and are to be resistant to moisture.

4.4.5.5 When rubber -like fillers arc used they are to consist of rubber (including regenerated and/or unvulcanized rubber) compounds or plastic compounds.

4.4.6 Sheaths and protective coverings

4.4.6.1 Cables are to be protected by one or more of the following, and the sheath or protective covering is to be compatible with the insulation:

- a. Sheath :
 - Lead-alloy sheath
 - Copper sheath
 - Non-metallic sheath

- b. Protective covering:
 - Steel-wire armour
 - Steel-tape armour
 - Metal-braid armour
 - Impregnated fibrous braid

4.4.6.2 Lead-alloy sheath is to be one of the recommended lead alloys given in IEC Publication 60092.

4.4.6.3 Copper sheath is permitted only for mineral-insulated cables.

4.4.6.4 Metal-braid armour is to be formed of galvanized steel, copper or copper alloy, or aluminium alloy wires. Aluminium alloy is to be corrosion resistant. The coverage density of the braid is to be such that the weight of the braid is at least 90% of the weight of a tube of the same metal having an internal diameter equal to the internal diameter of the braid and a thickness equal to the diameter of one of the wires forming the braid.

4.4.6.5 Steel-wire armour is to consist of galvanized annealed-steel wires having an elongation at break of at least 12%. The wires are to be applied over the bedding to form a uniformly cylindrical layer, and adequate flexibility of the cable is to be ensured.

4.4.6.6 Steel-tape armour is to consist of annealed-steel tape. In general, the armour is to be formed of two tapes wound over the bedding in the same direction so that the gap in the first layer is not more than half the tape width and the second layer covers this gap with an overlap.

4.4.6.7 Armour is to be protected against corrosion where necessary. A protective bedding is to be inserted beneath armour (of any type). This may be textile tape or braid, PCP tape or other suitable material. Textile materials are to be treated against moisture.

4.4.6.8 Polychloroprene compound, polyvinyl chloride compound and chlorosulphonated polyethylene may be used for non-metallic impervious sheath. Other compounds will be considered.

4.4.6.9 Textile braid is to be of cotton, hemp, asbestos, glass filament, or other equivalent fibre, and is to be of strength suitable for the size of the cable. It is to be effectively impregnated with a compound which is resistant to moisture, and flame-retarding.

4.4.7 Testing

4.4.7.1 Tests in accordance with the relevant standards accepted by the Society are to be made at the manufacturer's works prior to dispatch.

4.5 POWER AND LIGHTING TRANSFORMERS

4.5.1 General requirements

4.5.1.1 The requirements of this Section apply to the single phase transformers rated at 1 kVA or more and 3-phase transformers rated at 5 kVA or more.

4.5.1.2 All transformers, except those used for motor starting, are to be double wound, with no electrical connections between primary and secondary windings.

4.5.1.3 In general, transformers are to be of dry, air-cooled type. Proposal for the use of liquid cooled transformers are subject to special consideration of the Society.

4.5.2 Voltage regulation

4.5.2.1 The voltage drop in the secondary voltage between no load and rated load, under resistive load, is not to exceed the following:

- a. For single phase transformers rated more than 5 kVA or 3-phase transformers rated more than 15 kVA: 2.5%;
- b. For single phase transformers rated up to 5 kVA or 3-phase transformers rated up to 15 kVA: 5%

4.5.3 Parallel operation

4.5.3.1 Transformers arranged for parallel operation are to comply with the following requirements:

- a. Their winding connections are to be compatible;
- b. Their rated voltage ratios are to be equal (with tolerances within permissible limits);
- c. Their short-circuit impedance values are to be equal (if expressed in percentage, a ratio within 0.9 to 1.1 may be allowed);
- d. When transformers are intended for operation in parallel, the rated output of the smallest transformer in the group is to be not less than half of the rated output of the largest transformer in the group.

4.5.4 Temperature rise

4.5.4.1 The temperature rise of transformers at any part is not to exceed the values given in Table 4.5.4.1 during continuous operation at rated output, where the ambient air temperature is based on 45°C.

Table 4.5.4.1
Limit of temperature rise

Part of transformer		Limit of temperature rise(K)	Method of measurement
windings	Class A insulation	55	Resistance method
	Class E insulation	70	
	Class B insulation	75	
	Class F insulation	95	
	Class H insulation	120	
External surface of the iron core and structural components		Not to exceed the permissible temperature rise of the insulating materials which are in contact with them	Thermometer of thermocouple method

4.5.5 Short-circuits

4.5.5.1 All transformers are to be capable of withstanding, without damage, the thermal and mechanical effects of a short-circuit at the terminals of any windings for 2s.

4.5.6 Tests

4.5.6.1 The tests in 4.5.6.2 to 4.5.6.6 of this Section are to be carried out on all transformers at the manufacturer's works.

4.5.6.2 Temperature rise test

Transformers are to be tested for temperature rise at rated output. The limits of temperature rise are not to exceed the values given in Table 4.5.4.1.

4.5.6.3 High voltage test transformer are to be subjected to high voltage test by applying a test voltage between primary and secondary windings and between windings and the frame. The test is to be made with 1000 V A. C. plus twice the highest voltage between lines with a minimum of 2.0 kV at any frequency between 25 and 100 Hz and maintained for 1 min without break down and flash over.

4.5.6.4 Induced high voltage test Transformers am to withstand an induced high voltage test with a voltage twice the rated voltage and with an increased frequency equal to or greater than twice the rated frequency. The duration of the teat is to be obtained from the following formula with a minimum of 15s:

$$t = (60 \times 2 \times \text{rated frequency}) / \text{test frequency} \quad \text{s}$$

For transformers subject to temperature rise test, the induced high voltage test is to be carried out immediately after the temperature rise test.

4.5.6.5 Insulation resistance test

The insulation resistance test of each windings in turn to all the other windings, core, frame and tank or casing connected together and to earth is to be measured and recorded together with the temperature of the transformer at the time of the test.

4.5.6.6 Voltage regulation test

Transformers are to be subjected to voltage regulation test and the requirements of 4.5.2.1 are to be complied with.

4.5.6.7 Short-circuit test

Short-circuit test is to be carried out in accordance with the requirements of 4.5.5.1, if so required.

4.6 STORAGE BATERIES

4.6.1 General requirements

4.6.1.1 This Section is applicable to the permanently installed batteries.

4.6.2 Type

4.6.2.1 Storage batteries used on board ships may be of lead-acid or nickel-alkaline type. Other types of batteries are not to be put on board ships without the agreement of the Society.

4.6.3 Construction

4.6.3.1 All plates are to be of rigid construction, and are to be designed to reduce the shedding of active material to a minimum. The cells are to be so constructed as to prevent spilling of electrolyte due to an inclination of 40 normal, and to prevent emission of acid or alkaline spray.

4.6.3.2 The cells are to be grouped in crates or trays of rigid construction and suitable material and equipped with means to facilitate handling. The weight of the assembled batteries is not to exceed 100 kg. The requirement does not apply to the cell impossible to be assembled in the above-mentioned crates or trays due to its weight.

4.6.3.3 The emergency accumulator battery is to be so designed and arranged as to ensure that they will function satisfactorily at full rated power when the ship is upright or when inclined at any angle up to 22.5° to 10° either way in the fore or aft direction, or in any combination of angles within the aforesaid limits.

4.6.4 Nameplate

4.6.4.1 Each crate or tray is to be provided with a durable nameplate securely attached, bearing the manufacturer's name, type designation and date of dispatch, the ampere-hour rating at a specific rate of discharge (preferably that corresponding to the duty for the specific application 5, 10 or 20 h rating) and the specific gravity of the electrolyte (when the battery is fully charged in case of a lead-acid battery).

4.7 POWER SEMICONDUCTOR CONVERTORS

4.7.1 General requirements

4.7.1.1 This Section is applicable to power semiconductor convertors using semiconductor rectifying elements such as diodes, reverse blocking triode thyristors etc., and it does not apply to convertors for communication and the ancillary apparatus for instrumentation. The conversion may be from A.C. to D.C., from D. C. to A. C., from D. C. to D. C, and from A.C. to A.C.

4.7.1.2 Unless otherwise specified by the manufacturer, the maximum permissible temperature of junction of the rectifier cells is not to exceed the following values:

selenium diodes: 70 °C

silicon diodes: 150 °C

silicon thyristor: 100 °C (up to 50 A) ;
150 °C (more than 50 A).

4.7.1.3 Semiconductor convertors are preferably to be of the dry, air-cooled type.

4.7.1.4 Semiconductor convertors of the liquid-immersed type is preferably to be hermetically sealed. If provision is made for breathing, a suitable dehydrator is to be provided.

4.7.1.5 Transformers used in combination with semiconductor convertors are to be of two-winding transformers and are to comply with the relevant requirements of 4.5.

4.7.1.6 Semiconductor convertor stacks or semiconductor components are to be mounted in such a manner that they may be removed from equipment without dismantling the complete unit.

4.7.1.7 Fungus protection of the mercury-type is not to be used in the vicinity of the selenium rectifiers.

4.7.2 Protection

4.7.2.1 Where forced cooling is utilized, the circuit is to be so designed that power cannot be applied to or retained, on convertor stacks unless effective cooling is maintained, otherwise the semiconductor convertors are to stop operation.



4.7.2.2 Semiconductor convertors are to be capable of withstanding the effects of transient over-voltage from the ships network and the effects of D.C. voltage rise due to regenerated power.

4.7.2.3 Semiconductor convertors are to be protected against overload and short-circuit in accordance with the requirements of 2.5.14.1.

4.7.2.4 For liquid-immersed semiconductor convertors, consideration is to be given to provide liquid over temperature alarm and gas-actuated protection devices.

4.7.3 Testing

4.7.3.1 Semiconductor convertors are to be tested at the manufacturer's works in accordance with the requirements of 4.7.3.2 to 4.7.3.5. However, the test required in 4.7.3.2 may be omitted for the products produced in series, subject to agreement of the Society.

4.7.3.2 Semiconductor convertors are to be subjected to temperature rise test under normal working conditions.

4.7.3.3 Semiconductor convertors are to be subjected to an operating test.

4.7.3.4 Semiconductor convertors are to withstand a high voltage test with the following testing voltage (with a minimum of 2000v):

$$U_p = 2 \times \frac{U_m}{\sqrt{2}} + 1\,000 \quad \text{V}$$

Where:

U_p - the effective value of testing voltage, V;

U_m - the maximum no-load peak value between any pair of terminals of semiconductor convertors, if the voltage to earth is higher than the voltage between two terminals (e.g. the convertors are connected in series) , the higher voltage is taken.

But if $U_m/\sqrt{2}$ is less than 90 V, U_p is to be taken as 1000 V.

This testing voltage is to be alternating at any frequency between 25 and 100 Hz and is to be applied between the live parts and any non-current carrying metal parts which may be earthed for a period of 1 min without break down or flash over.

4.7.3.5 The insulation resistance between live parts of convertors or their accessories and earth is not to be less than 1 M Ω when tested with a D.C. megameter of 500 V .

4.8 OTHER ELECTRICAL EQUIPMENT

4.8.1 Incandescent lighting

4.8.1.1 The voltage and load of tungsten filament lampholders are not to exceed the values specified in Table 4.8.1.1

Table 4.8.1.1
Voltage and load of tungsten filament lamps

Type of lampholders		Voltage (V)	Load
Bayonet cap	B22	250	200W/4A
	B15d	250	15W/2A
	B15s	55	15W/2A
Screw cap	E40	250	3000W/16A
	E27	250	200W/4A
	E14	250	15W/2A

4.8.1.2 Lampholders are to be constructed of flame-retarding and non-hygroscopic material. All metal parts are to be of robust construction. E40 lampholders are to be provided with means for locking the lamp in the holder.

4.8.1.3 The lighting fittings are to be so constructed as to ensure that the temperature of the incoming cables is not to exceed the maximum rated conductor temperature given in Table 2.12.2.2.

4.8.2 Discharge lamp luminaires operating at voltages below 250 V

4.8.2.1 All independent ballasts, capacitors and other auxiliaries mounted separately from the luminaire are to be enclosed in an earthed metal casing.

4.8.2.2 Capacitors of 0.5 μ F and above are to be provided with a means of prompt discharge on disconnection of the supply.

4.8.2.3 The voltage and load of the fluorescent lighting lampholders are not to exceed the values specified in Table 4.8.2.3.

Table 4.8.2.3
Voltage and load of fluorescent lighting

Type of lampholders	Voltage (V)	Load (W)
G13	250	80
GS	250	13

4.8.2.4 The construction of fluorescent lighting lampholders is to comply with the requirements of 4.8.1.2.

4.8.3 Discharge lamp luminaires operating at voltages above 250 V

4.8.3.1 All fittings of discharge lamps are to be of robust construction.

4.8.3.2 All live parts of discharge lamp luminaires are to be so designed, placed and installed that they cannot be touched accidentally or inadvertently, and the creepage distance along the surface of the glass tube is to be taken into consideration.

4.8.3.3 Transformers for discharge lamps are to have their primary and secondary windings electrically separated and are not to contain flammable liquid.

4.8.3.4 Transformers are to be placed within the discharge lamp luminaire or located as closely as possible to the luminaire installation.

4.8.3.5 The notice boards bearing the inscription "DANGER! HIGH VOLTAGE!" are to be provided in accordance with 2.7.1.4.

4.8.4 Navigation lights and other signal lights

4.8.4.1 The navigation lights and other signal lights are to comply with the relevant requirements of the current International Regulations for Preventing Collision at Sea.

4.8.5 Heating and cooking appliances

4.8.5.1 Heating elements are to be provided with guards of robust construction. The openings of the protective guard are to be sufficiently narrow to prevent the falling-in of foreign particles.

4.8.5.2 The heating and cooking appliances are to be so constructed as to ensure that the supply cable terminals are not increased in temperature above the maximum rated conductor temperature given in Table 2.12.2.2.

4.8.5.3 Internal connection wires of the heating and cooking appliances are to be continuously insulated with incombustible material. Electrical connections between heating elements are not to be effected by soldering.

4.8.5.4 The insulation resistance of heating and cooking appliances in hot condition is not to be less than 5m.

4.8.5.5 Electrical heating and cooking appliances are to be so constructed that parts which must necessarily be handled in use cannot become heated to a temperature exceeding the values given in Table 4.8.5.5.

Table 4.8.5.5
Allowable maximum temperature

Handles, grips and the like made of	Maximum temperature during normal use held in hand (°C)	
	For long period	For short period
Metal	55	60
Porcelain, vitreous material, moulded material, rubber or wood	65	70

4.8.5.6 Heating and cooking appliances and their control gear fitted in galley spaces are to have a degree of protection of at least IP44. Their enclosures are to be corrosion-resistant and provided with one or more drainholes.

4.8.5.7 Cooking appliances are to be so constructed that spilling or over-flowing of liquid or food will not cause short-circuits or insulation failures.

4.8.5.8 Space-heating appliances are to be so constructed, protected and installed that clothing, bedding and other combustible material cannot come in contact with them in such a manner as to cause risk of fire. Furthermore, they are to be so constructed that combustible material cannot be placed over the top of their enclosures.

4.8.5.9 Space-heating appliances are to be equipped with means to interrupt the current when the temperature exceeds the permissible limit.

4.8.6 Accessories

4.8.6.1 Accessories are to be so designed and constructed that the passages for the insulated conductors are of ample size and free from rough projections, sharp angles, and abrupt bends. All outlets for cables are to have well-rounded edges or be suitably bushed.

4.8.6.2 Accessories are to be so designed, and the insulated conductors are to be so installed that stress cannot be applied by the conductors to any terminal to which the conductors may be connected.

4.8.6.3 Accessories are to be so designed and fixed that dust and moisture cannot readily accumulate on live parts and their insulation.

4.8.6.4 Enclosures are to be made of metal or flame-retardant insulating material.

4.8.6.5 The construction of plugs and socket-outlets is to comply with the following requirements:

- a. The temperature rise of the live parts of plugs and socket-outlets is not to exceed 30 °C.
- b. They are to be so constructed that the live parts cannot be touched by the operator when the plug is being inserted in, and that it is impossible to insert only one pin of the plug into the socket-outlet.
- c. They cannot be readily short-circuited whether the plug is in or out, and a pin of the plug cannot be made to earth either pole of the socket-outlet.
- d. All plugs or socket-outlets with a working voltage exceeding 50 V are to be provided with a pin and jack for earthing connection. The cross-section and the length of the earthing pin on the plugs are to be greater than those of other pins.
- e. Plugs and sockets with different working voltages are to be of different types.

4.8.6.6 Socket-outlets for a rated current in excess of 16 A are to be interlocked with a switch such that the plug cannot be inserted or withdrawn when the switch is in the on position.

4.8.6.7 Socket-outlets and plugs with a degree of protection of IP56 are to be provided with means to maintain the same degree of protection whether the plug is inserted or removed.

CHAPTER 5: SUPPLEMENTARY REQUIREMENTS FOR SMALL SHIPS AND SHIPS IN RESTRICTED SERVICE

5.1 GENERAL REQUIREMENTS

5.1.1 General requirements

5.1.1.1 The requirements of this Chapter are applicable to electrical installations on the following ships, and may be as a substitution for the related aforesaid requirements in this PART:

- a. Cargo ships with class notations of greater coastal service, coastal service or navigating in the equivalent service but not engaged on international voyages;
- b. Ships with class notations of sheltered water service or navigating in the equivalent service;
- c. Cargo ships of less than 500 gross tonnage.

5.2 SHIPS ENGAGED ON NON-INTERNATIONAL VOYAGES AND IN COASTAL AND GREATER COASTAL SERVICES

5.2.1 Earth indicator

5.2.1.1 For ships of less than 1600 gross tonnage other than those carrying dangerous goods such as oil tankers intended for the carriage of dangerous goods, an earth indicator may be used instead of an alarm device for monitoring the insulation resistance as required in 2.4.2.2.

5.2.2 Main source of electrical power

5.2.2.1 The minimum comfortable conditions of habitability as required in 2.1.1.1(b) need not be complied with.

5.2.2.2 Where the total capacity of the main generator is 400 kW or below, main bus-bar may not be subdivided as required in 2.1.1.1(d) and (e).

5.2.3 Emergency source of electrical power

5.2.3.1 Independent emergency sources of electrical power are to be provided in all passenger ships and cargo ships of 1 600 gross tonnage and over, unless otherwise stated in 5.3.3.1.

5.2.3.2 The period of power supply of the emergency source of electrical power as required in 2.2.2.1 and 2.2.3.1 may be reduced to:

- a. For ships in greater coastal service: 12 h for passenger ships, and 6 h for cargo ships.
- b. For ships in coastal service: 6 h for passenger ships and 3 h for cargo ships.

5.2.3.3 The emergency lighting as required in 2.2.3.1(a) and (b) may be complied with:

- a. At every muster and embarkation station and over the sides (may be only 2 h for cargo ships);
- b. In all alleyways, stairways and exits;
- c. In machinery spaces and at emergency switchboards;
- d. In all control stations.

5.2.4 Spare power sources

5.2.4.1 Where emergency sources of electrical power is not provided for ships of 1 600 tons gross tonnage or below as required in 5.2.3, independent spare power source in compliance with the requirements of 5.2.4 is to be provided.

5.2.4.2 Spare power source is to be the accumulator batteries in compliance with the following requirements:

- a. Not to be in the same space where the main source of electrical power and to be erected above the highest continuous deck as far as practicable;
- b. To comply with the requirements of 2.2.1.4(a), (b) and 1.2.1.1(b).
- c. To be capable of providing immediately power supply for any equipment as required in 5.2.4.3.

5.2.4.3 The capacity of spare power sources is to meet the requirement for power supply of at least 3 h for the following equipment:

- a. Lighting for muster and embarkation stations of lifeboats and liferafts, outside, all the corridors, stairways and exists and spaces for main switchboard, spare power source and control station;
- b. Navigation lights and other lights as required in International Regulations for Preventing Collisions at Sea;
- c. Internal communication equipment required in emergency;
- d. Fire detection and fire alarm system (if any);
- e. For intermittent operation of the daylight signaling lamp, the ships whistle, the manually operated call points and all internal signals that are required in an emergency (e .g. general alarms, etc.);
- f. Radio communication equipment on board.

5.2.5 Lighting

5.2.5.1 For cargo ships, the compartments and spaces to be supplied by two final sub-circuits as required in 2.7.2.2 may be reduced to the main engine room and boiler room, and one of the circuits may be used for emergency lighting.

5.2.6 Steering gear

5.2.6.1 The steering gear may comply with the relevant requirements of these regulations.

5.2.7 Application of fire-retardant cables

5.2.7.1 Except for passenger ships carrying less than 100 passengers and cargo ships of less than 1 600 gross tonnage, the fire-retardant cables required in 2.12.3.4 and 2.12.3.5 are applicable to the passenger ships carrying 100 passengers or more and the cargo ships of 1 600 gross tonnage and over.



5.2.8 Supply of control box for navigation lights

5.2.8.1 The control box of navigation lights is to be supplied by the main switchboard and emergency switchboard (01 temporary switchboard).

5.3 SHIPS NAVIGATING IN SHELTERED WATER SERVICE

5.3.1 General requirements

5.3.1.1 The requirements in 5.2.1.1, 5.2.2.1, 5.2.2.2, 5.2.5.1 and 5.2.7.1 and the following additional requirements are applicable.

5.3.2 Main source of electrical power

5.3.2.1 Main source of electrical power is to be in compliance with the following requirements:

- a. Only one generator may be fitted in cargo ships.
- b. If all kinds of auxiliary machinery serving the main engine, oil pump for engines, steering gear, fire pump and bilge pump are driven by main engine, only one generator set may be fitted in passenger ships.

5.3.3 Reserve source

5.3.3.1 Emergency sources of electrical power as required in Section 2 of Chapter 2 of this PART may not be fitted, but an independent spare power sources in compliance with the requirements of 5.2.4.2 and 5.2.4.3 is to be fitted, and supply period is 1 h.

5.3.4 Supply of control box for navigation lights

5.3.4.1 The control box for navigation lights is to be supplied by the main switchboard and the reserve source.

5.4 CARGO SHIPS OF LESS THAN 500 GROSS TONNAGE

5.4.1 General requirements

5.4.1.1 The alarm for the control box for navigation lights specified in 5.2.1.1, 5.2.2.1, 5.2.2.2, 5.2.5.1, 5.2.7.1 and the following additional requirements are applicable.



5.4.2 Distribution systems

5.4.2.1 In addition to the distribution systems as listed in 2.4.1.1, an A. C. three-phase four-wire insulated system may be used.

5.4.3 Reserve source

5.4.3.1 Emergency source of electrical power as required in 2.2r may not be fitted, where as an independent spare power source in compliance with 5.2.4.2 and 5.2.4.3 is to be fitted.

5.4.4 Control and supply of navigation lights

5.4.4.1 The alarm for the control box for navigation lights as specified in 2.7.4.4 need not be required.

5.4.4.2 The control box for navigation lights is to be supplied by the main switchboard and the reserve source.

5.4.5 Alarm system

5.4.5.1 The general emergency alarm system required in 2.9.1 can only be operated in the navigation bridge.

5.4.5.2 Engineers alarm system required in 2.8.4 may not be provided.

■ **Panama Head Office**

Address: No.0750-D Williamson
Place
La Boca, Balboa,
Panama, Rep. of Panama.
E-mail: omcs@omcsclass.org
Telephone: (507)314-1756 / 52
Telefax: (507)314-1757
24 / 7 Contact (507) 6780-5046
Number: (507) 6676-8505
Mail Address: P.O. Box 0843-02416,
Balboa, Ancon, Panama.

■ **Far East Regional Office (FERO)**

Address: Room 1506, Suncome
Liauw 's Plaza, No. 738,
Shangcheng Road,
Pu-Dong New Area;
Shanghai, R.P.C.
E-mail: china@omcsclass.org
Telephone: (86) 21 58360772 / 73
Telefax: (86) 21 58360772 - 616
(86) 21 58360773 - 616
24 / 7 Contact
Number: (86) 18721978211

■ **Middle East Regional Office (MERO)**

Address: P. O. Box 487211,
Dubai / UAE
E-mail: dubai@omcsclass.org
24 / 7 Contact
Number: (971) 501048562

www.omcsclass.org